

# Air Circulation Fans



**hydor**

# Turbulator Range



HTS 14 - HTS 24

## Introduction

Hydor's brand leading range of Turbulator fans comprise four variants, all specifically designed to have a long throw and move air efficiently, to give a measure of control over temperature and humidity in glasshouses, polythene tunnels, poultry, turkey, calf and pig housing, potato stores and industrial buildings.

Still air conditions can lead to problems in these buildings causing unhealthy conditions for crops, animals and humans.

Expiration and transpiration increase humidity of the air near plants and animals, so the plants become endangered by fungoid diseases and the animals are prone to heat exhaustion in summer, cold and damp in the winter.

Turbulator's give sufficient light air movement to counteract the effects of such conditions, by improving air distribution, reducing air temperature stratification, increasing air velocity in the plant / animal zone as well as eliminating dead air spots.

The HTL 20 has an extended casing length, specifically developed in the Turbulator range to provide an increased throw of circulated air for those applications required. This is achieved with a more settled airflow pattern as the air discharges from the fan outlet.

This Turbulator variant is supplied with an Alu-Zinc casing as standard, but is available in Stainless steel for more corrosive environments.

## HTL 20

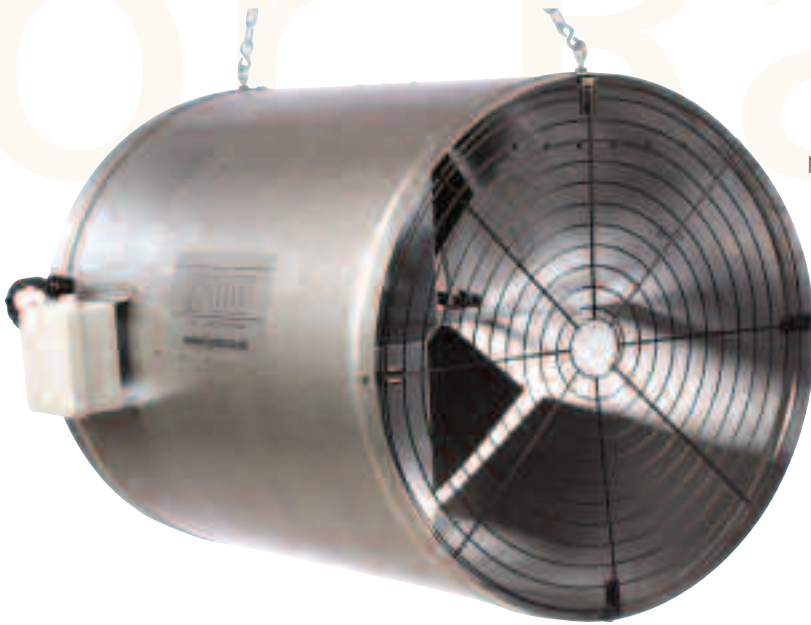

## HTHB 20

The HTHB 20 is a long cased Turbulator complete with an electric heater battery and integrated controls. The HTHB features include;

Economy in space as it is suspended rather than floor mounted, which is particularly suited to horticultural applications where the heated air does not blow directly onto the plants which ensures they are not vulnerable to drying out.

Thermostat with three settings;

1. Fan only - Summer Only
2. Fan heater constant - Severe winter mode
3. Fan with heater on thermostat - Frost protection

The integrated control panel is attached to the housing of the fan unit.



## THE RANGE

The standard Turbulator HTS range opposite, comprises five model sizes from 355mm to 630mm diameter, producing air volumes of up to 2.86 m<sup>3</sup>/s.

This established range of Turbulators has been complimented with the addition of three other variants, from Stainless steel casings for more corrosive environments, to Heater versions with integrated controls, to long cased options that meet customer's precise market applications in air circulation.

Each of the three Turbulator variants are available with a standard 500mm diameter fan, providing performances of up to 1.37 m<sup>3</sup>/s. Hydor's capabilities in manufacturing and design extend well beyond this, enabling us to provide additional sizes or bespoke requirements upon request.



## HTSS 20

The HTSS 20 is a short cased Turbulator, providing duties of up to 1.37m<sup>3</sup>/s, with a stainless steel casing ensuring a maintenance free, long service life of the product for a variety of applications such as pig farming, where vulnerability to corrosion exists.

# Turbulator Features & Benefits

- Designed To prevent heat stratification, thereby reducing heating costs by re-circulating the warmer air away from the ceiling of the building.
- Eases higher temperature situations where circulating air moves body heat of plants and animals faster than still air. An air speed of 2.5m<sup>3</sup>/s reduces the perceived air temperature by 5°C (10°F).
- Prevents areas of stagnant air building up which can lead to problems in the health of plants and animals.
- Waterproof Junction box and 3 metre cable.
- Stainless steel casings are available for particularly corrosive applications.

- There are two types of Turbulator casing construction, standard Alu-Zinc, which is a flat steel product coated with an aluminium alloy on both sides using a continuous dipped process. The coating creates a permanent screening, whilst retaining an attractive finish.
- Stainless steel casings are available for particularly corrosive applications.



Alu-Zinc



Stainless Steel

- Large range of thermostats and speed controllers available.
- 12 months product warranty.
- Turbulators provide Low energy consumption for farmers and growers alike.
- Turbulators are supplied for horizontal mounting as standard, although vertical mounting arrangements can be supplied upon request.
- The quiet operation of the Turbulator provides a more stable working environment for staff to work within.
- The standard Turbulator comprises 5 sizes, 355mm to 630mm, providing flexibility in selection, for smaller air circulation applications, where size and placement may be a consideration, to larger volume commercial requirements such as glasshouses

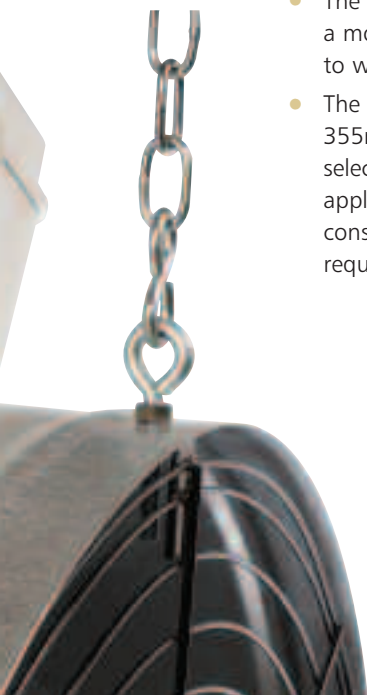

- Suspension eyes and chain for ease of mounting.

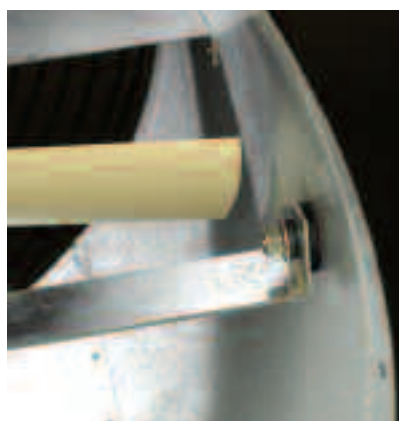

- Rust proof air straightener for long axial air flow.

- Rust proof wire guards for employee safety



## Accessories



- A full range of both automatic and manual infinitely variable controllers.
- A full range of electronic/manual thermostats.
- Extra chain/cable available - please notify at time of ordering.

## Specification

### Casing

The standard casings and motor supports are manufactured from Alu-Zinc to BS EN 10215: 1995.

Stainless steel casings and motor supports are manufactured from 304L grade stainless steel

### Motors

The Turbulator is driven by a highly efficient, lightweight induction motor, with sealed for life, maintenance free ball bearings. Each motor is specifically matched to the aerodynamic performance of the impeller. Motors are Class 'F' insulated, weather proofed to IP55 and are suitable for speed control. The fan is suitable for use in ambient operating temperatures of up to 50°C.

Motor guards are manufactured from mild steel, zinc plated prior to powder coating black and conform to BS 848 Part 5.

The electrical connection to the motor is provided by a pre-wired plug attached to three metres of cable. This cable is terminated into an IP55 terminal box fitted onto the other side of the fan casing.

### Impellers

Fixed pitch aerodynamic impellers are provided, manufactured from high quality glass reinforced polypropylene (GRP). These impellers are selected at an angle to provide maximum performance. Assembled impellers are to be balanced to Grade G6.3

### Mounting

The fan is supplied with hanging chains (0.5m long on all except HTS 24 which is 1.0m) for horizontal operation.

### Heating

The Turbulator HTHB20 is supplied with an electric heater battery and integrated controls

Elements are constructed from Nichrome 5 spiral resistance wire surrounded by magnesium oxide powder and stainless steel. The elements are mounted on a galvanised sheet steel terminal housing. All electric heaters are fitted with high temperature thermal cut out protection for wiring into the control circuit and are generally available in the power and number of steps required. A control system is provided to ensure the heater is not activated when there is no airflow and the fan runs on after the heater has been switched off, to dissipate any residual heat.

A fan run on timer is incorporated within the controls to prevent possible heat damage.

### Quality Management

All units are designed and manufactured with procedures as defined in BS EN ISO 9001: 2000. All Turbulator models are to be tested to ISO 5801: 1997 (airside performance) and BS 848 Pt 2:1985 (sound performance).

# Market Air

## Livestock Housing Benefits

When Hydor Turbulators are used for redistribution of air in livestock buildings the units are fitted with a special deflector plate which directs the air to the sides of the building. The units are mounted either horizontally or vertically and when used for heat redistribution, the fans suck downwards from the apex area, forcing the hot air from the apex out to the sides and recirculating back towards the centre. In summertime the fans are lowered by means of pulleys to force air downwards along the centre of the house, thus creating turbulence and redistributing the lower strata of air.

### Heat stratification in a typical broiler house

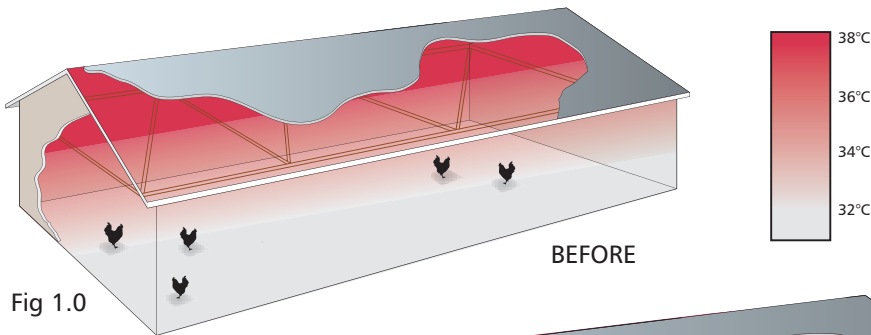

Fig 1.0

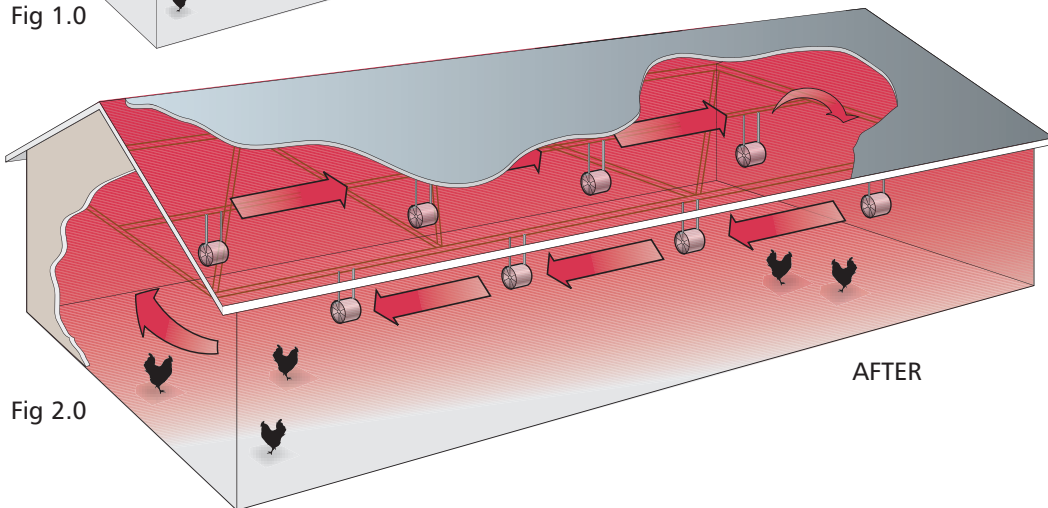

Fig 2.0

## Poultry

Turbulators are mounted horizontally at height to equalise temperatures within a poultry house during the breeding cycle, when birds are small and little or no external air is required. In hotter conditions where open sided poultry houses are used these units can be used to provide air movement along or across the passageways.

Fig 1.0 highlights the temperature stratification without air circulation.

Figure 2.0 illustrates the benefits of installing Turbulators, culminating in more even temperatures throughout the broiler house.

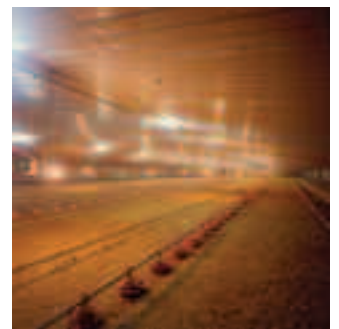

## Pigs

Within dry sow, heavy hog accommodation, the use of Turbulator fans can be introduced to enhance air circulation by blowing air onto the pigs in particularly hot summer conditions.

There are a number of distinct benefits for piggery applications with this particular product, namely –

- Control of insects – Many insects and flies are discouraged by a constant airflow throughout the pig building which is created by Turbulator fans.
- Overcomes dunging problems – Where the ventilation rates become too low, pigs will tend to congregate wherever the oxygen level is best in their housing. Turbulators gently circulate fresh air evenly throughout the entire building, which culminates in a healthier environment for the pigs.
- A reduction in heat stress, whereby growth loss is reduced from heat stress.
- A constant airflow will ensure the pig building is kept dry by increasing evaporation of moisture in the air.
- A reduction in the heat stress of pigs when using Turbulators to circulate the air can enhance their reproductive efficiency.
- Air circulation moves ammonia fumes away from the pigs, thereby circulating gases to a higher level within the building, which in turn means that exhaust fans will remove them from the building more efficiently.



# Applications

## Market Applications



### Dairy

The Turbulator range is ideally suited for milking parlours that can become hot and humid in summer months, which will encourage flies, as well as calf housing where additional fan powered ventilation will ensure a constant supply of fresh air into the building.

The Turbulator provides the following benefits;

- 'Blow' flies away from livestock and out of the dairy
- Keeps dairy workers cool
- Removes stale and humid air from the workplace
- Disperses dust from feed systems
- The Turbulator can be mounted at any angle for optimum coverage in any dairy.

### Industrial & Commercial

Turbulators provide a wide variety of benefits to the industrial and commercial sectors, in particular, the de-stratification of temperature layers improves occupants comfort as well as reducing overall heating and cooling costs.

### Crop Storage

Turbulators can keep air movement circulating around a particular crop, for example, potatoes, especially in the corners of the building.

In the case of potato storage, a polythene tube is fitted to the vertically mounted Turbulator units which brings the air from high level to localised low level and achieves even temperature and humidity.

Helps keep condensation under control, thereby minimising rejection in crop quantity due to rot.



# Market Applications

## Glasshouse and Polythene Tunnels

Depending on the size and shape of the glasshouse and height of the crop, a number of horizontally mounted Hydor Turbulators will provide the required air movement over the whole area at minimal consumption of electricity. Good distribution of CO<sub>2</sub> is also ensured by the units, thus helping to keep the overall figure as near as possible to 0.03%. Plastic tubes can easily be fitted to the outlet of the fan if more positive air distribution is required.

The Turbulator range is designed to prevent temperature stratification in glasshouses, producing higher and more uniform temperature arrangements at crop level as illustrated in the drawing / Figure 3.0 below. This has the benefit of providing growers with improved output and quality of crops, alongside reduced labour costs and more comfortable working conditions in the glasshouse for tasks requiring human skills.



## 'Turbulator' Horizontal Air Flow Arrangements

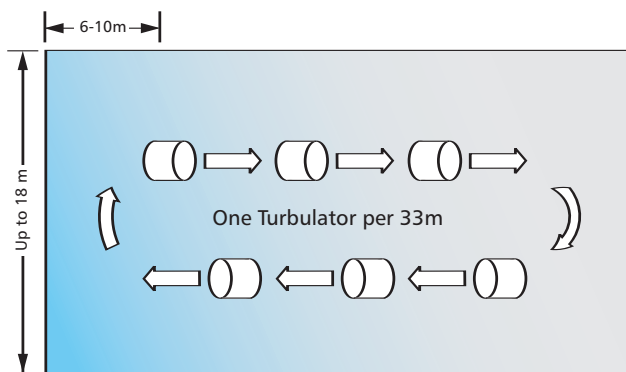

Figure 3.0

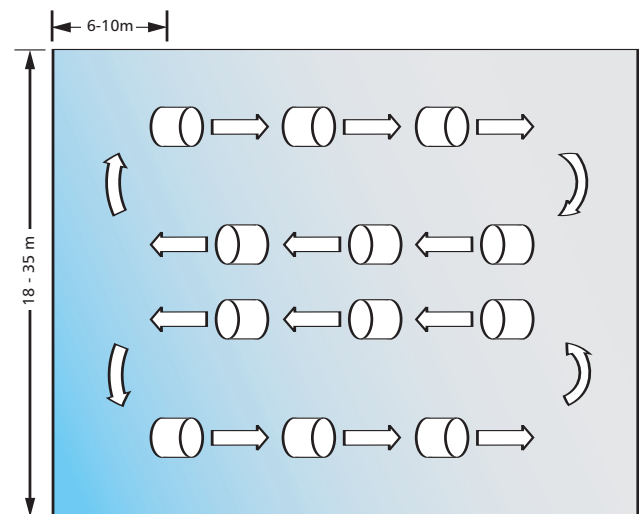

Figure 4.0

Figure 3.0 and 4.0 illustrate typical Horizontal air flow arrangements for a series of Turbulators within a glass house application.

A Horizontal air flow arrangement within the building ensures air stratification is virtually eradicated by ensuring the air is sufficiently mixed to provide even temperatures throughout the glasshouse.

The de-stratification of heat within the building in the winter months provide lower heating costs to the grower.

The corners of horticultural buildings are always vulnerable to hot and cold spots dependent upon the time of year, however, Turbulators circulate air efficiently to these areas which minimizes the need for spraying to prevent plant diseases created by moisture condensation on the plants, ensuring a more evenly spread, mature crop.

Although humidity levels within a glasshouse are not reduced, a Turbulators efficiency in air circulation ensures the humidity, as with temperature, is evenly spread in the building, which means lower humidity levels are achieved across the crops.

# Turbulator HTS / HTSS

## Dimensional Data

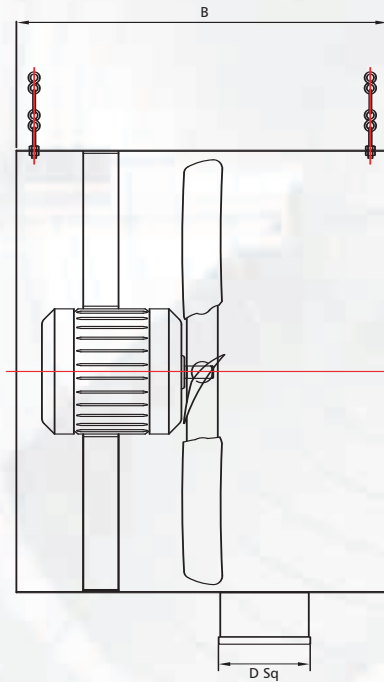
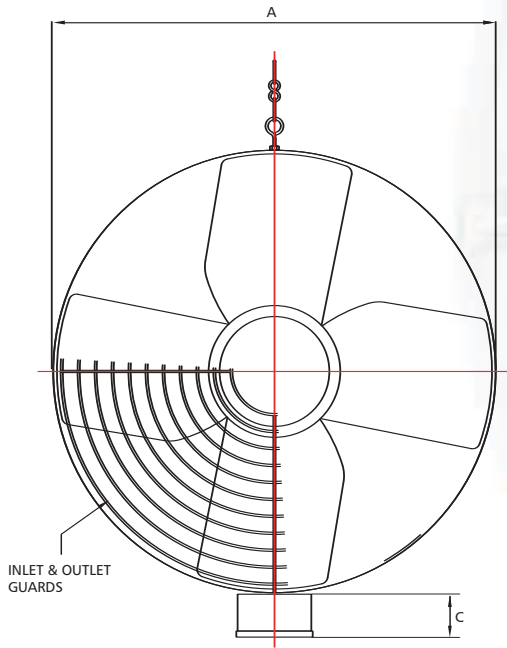

Product Model	A	B	C	D	Weight (kg)
HTS 14	360	420	75	115	10
HTS 16	410	420	75	115	13
HTS 18	460	420	75	115	15
HTS 20	510	420	70	115	16
HTS 24	660	420	70	115	29

Product Model	A	B	C	D	Weight (kg)
HTSS 20	510	420	70	115	16

N.B. All Dimensions are expressed in millimetres

N.B. All Dimensions are expressed in millimetres

## Performance & Electrical Data

Product Model	Fan Dia (mm)	Speed (r/min)	Airflow (m <sup>3</sup> /s)	Throw (metres)	Noise Level dBA @3m	FLC Amps	Supply V-Ph-Hz
HTS 14/4	355	1350	0.86	30-35	57	1.1	230-1-50
HTS 16/6	400	900	0.89	30-35	52	0.8	230-1-50
HTS 16/4	400	1350	1.27	35-40	62	1.6	230-1-50
HTS 18/6	450	900	1.12	35-40	54	1.0	230-1-50
HTS 18/4	450	1350	1.70	40-45	64	1.9	230-1-50
HTS 20/6	500	900	1.37	40-45	56	1.0	230-1-50
HTS 24/6	630	900	2.86	45-50	60	1.2	230-1-50

Product Model	Fan Dia (mm)	Speed (r/min)	Airflow (m <sup>3</sup> /s)	Throw (metres)	Noise Level dBA @3m	FLC Amps	Supply V-Ph-Hz
HTSS 20/6	500	900	1.37	40-45	56	1.0	230-1-50

Product Model	Control method	N° fans *
HVMRD	Manual speed control	1-6
HVARC	Temperature, variable speed	1-6
HVARC /P	Temp, OFF/variable speed	1-6
HVARC /HI	As VARC plus heater interlock	1-6
HVARC /HP	As VARC /HI plus fan OFF	1-6

\* Please specify when ordering



A single fan, manual speed regulator HVMRD with overload protection - models available for up to six fans.

Also available is the HVARC range of automatic speed controllers with thermistor temperature sensor, for small animal production houses using from one to six fans.

# Turbulator HTHB

## Dimensional Data

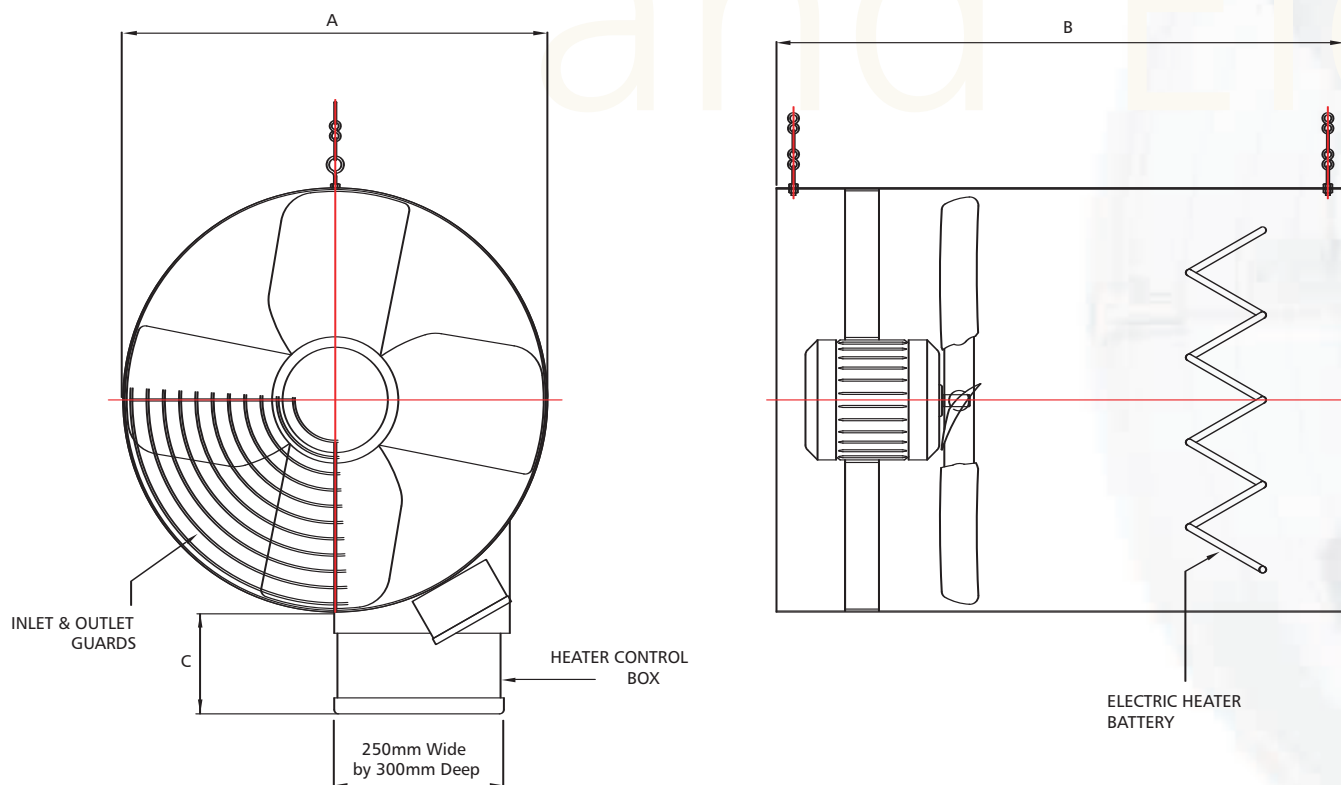

Product Model	A	B	C	Weight (kg)
HTHB 20	510	670	140	21

N.B. All Dimensions are expressed in millimetres

## Performance & Electrical Data

Product Model	Fan Dia (mm)	Speed (r/min)	Airflow (m <sup>3</sup> /s)	Heat Output (Watts)	Throw (metres)	Noise Level dBA @3m	FLC Amps	Heater Amps (Max)	Supply V-Ph-Hz
HTHB 20/6	500	900	1.37	2500	45-50	56	1.0	10.9	230-1-50

Product Model	Control method	N° fans *
HVMRD	Manual speed control	1-6
HVARC	Temperature, variable speed	1-6
HVARC /P	Temp, OFF/variable speed	1-6
HVARC /HI	As VARC plus heater interlock	1-6
HVARC /HP	As VARC /HI plus fan OFF	1-6

\* Please specify when ordering



A single fan, manual speed regulator HVMRD with overload protection - models available for up to six fans.

Also available is the HVARC range of automatic speed controllers with thermistor temperature sensor, for small animal production houses using from one to six fans.

# Performance

## Turbulator HTL Dimensional Data

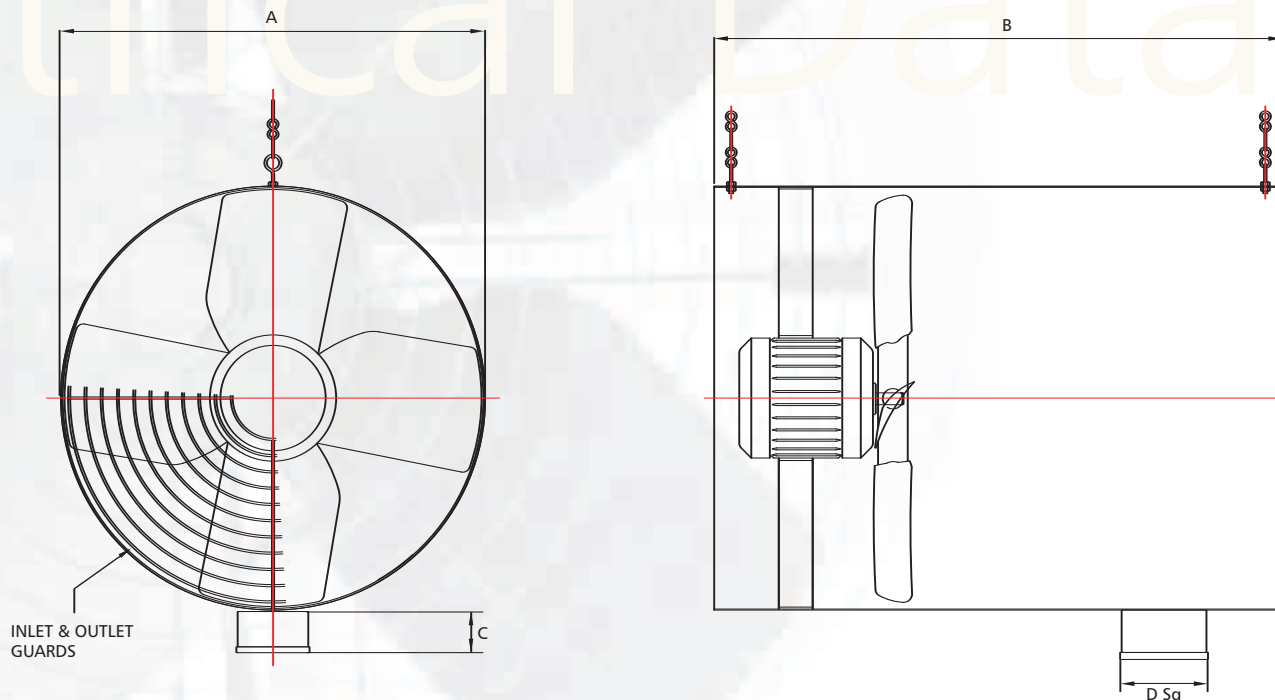

Product Model	A	B	C	D	Weight (kg)
HTL 20	510	670	70	115	17

N.B. All Dimensions are expressed in millimetres

## Performance & Electrical Data

Product Model	Fan Dia (mm)	Speed (r/min)	Airflow (m <sup>3</sup> /s)	Throw (metres)	Noise Level dBA @3m	FLC Amps	Supply V-Ph-Hz
HTL 20/6	500	900	1.37	45-50	56	1.0	230-1-50

Product Model	Control method	N° fans *
HVMRD	Manual speed control	1-6
HVARC	Temperature, variable speed	1-6
HVARC /P	Temp, OFF/variable speed	1-6
HVARC /HI	As VARC plus heater interlock	1-6
HVARC /HP	As VARC /HI plus fan OFF	1-6

\* Please specify when ordering



A single fan, manual speed regulator HVMRD with overload protection - models available for up to six fans.

Also available is the HVARC range of automatic speed controllers with thermistor temperature sensor, for small animal production houses using from one to six fans.



[www.hydor.co.uk](http://www.hydor.co.uk)

Hydor Ltd · Unit 8 · Parkers Close · Downton Business Centre  
Downton · Salisbury · Wiltshire · SP5 3RB  
Tel: +44 (0) 1725 511422 · Fax: +44 (0) 1725 512637  
e-mail: [info@hydor.co.uk](mailto:info@hydor.co.uk) · [www.hydor.co.uk](http://www.hydor.co.uk)

HCF/02-05-06/01

FANS

CONTROLS

SYSTEMS