

Air Valves



hydor

HEV & HSV Air Valves

The Hydor HEV & HSV range of steel air valves present a straightforward and efficient way of providing discharge and supply of air, with excellent performance characteristics and a stylish design, which means they are suitable for the majority of industrial, commercial and domestic ventilation applications.

Typical examples of Building services applications for air valves would range from banks, cinemas and libraries to apartments, offices, schools and hospitals.

- Totally adjustable cone.
- First-rate pressure drop and noise characteristics.
- Swift, yet simple valve removal for cleaning and maintenance.
- Mounting rings supplied complete with valve.
- Locking nut to maintain airflow setting.
- A durable white stove enamelled finish.



Size Range

Hydor air valves are available as 4 standard sizes, from 100mm (4") to 200mm (8") for both extract and supply which ensures the correct selection for the specific application.

Construction

Hydor air valves are manufactured from sheet steel with a highly durable stove enamelled material finish, which provides the benefits of being anti-static and corrosion resistant, so they are suitable for higher humidity environments such as bathrooms, kitchens, utility rooms and toilets.

VAIRVALV

Features and Benefits

Mounting arrangements

All Hydor air valves are designed for either wall, ceiling or duct mounting applications, which means greater flexibility with installations.

Inner Cone

The HEV / HSV models comprise an inner cone which is convex in shape to benefit discharge systems, whereas HSV models differentiate by design with concave inner cones for supply systems.

Fixing arrangement

Each extract or supply valve is supplied complete with a 50mm zinc plated mounting ring. The mounting ring is designed so that it can be firmly fixed in position into a duct or opening.

Having secured the mounting ring into the correct position, the valve should be rotated so that it locates the grooves in the mounting ring.

By doing this, the valve is retained on the mounting ring, which also creates an airtight seal as the foam gasket between the mounting ring and valve is compressed.

Airflow adjustment

The airflow rate of the valves can be adjusted by simply turning the inner cone either inwards (Clockwise) or outwards (Anti-clockwise).

Having determined the airflow setting, the inner cone is secured in position with an integral locknut which ensures the airflow is securely maintained.

Cleaning & Maintenance

Routine maintenance and cleaning is far easier as the valve can be easily removed, cleaned, then replaced without actually affecting the adjustment of the valve and its performance.

Warranty

All HEV & HSV valves have a 12 month warranty.



Dimensional Drawings

Extract Valves

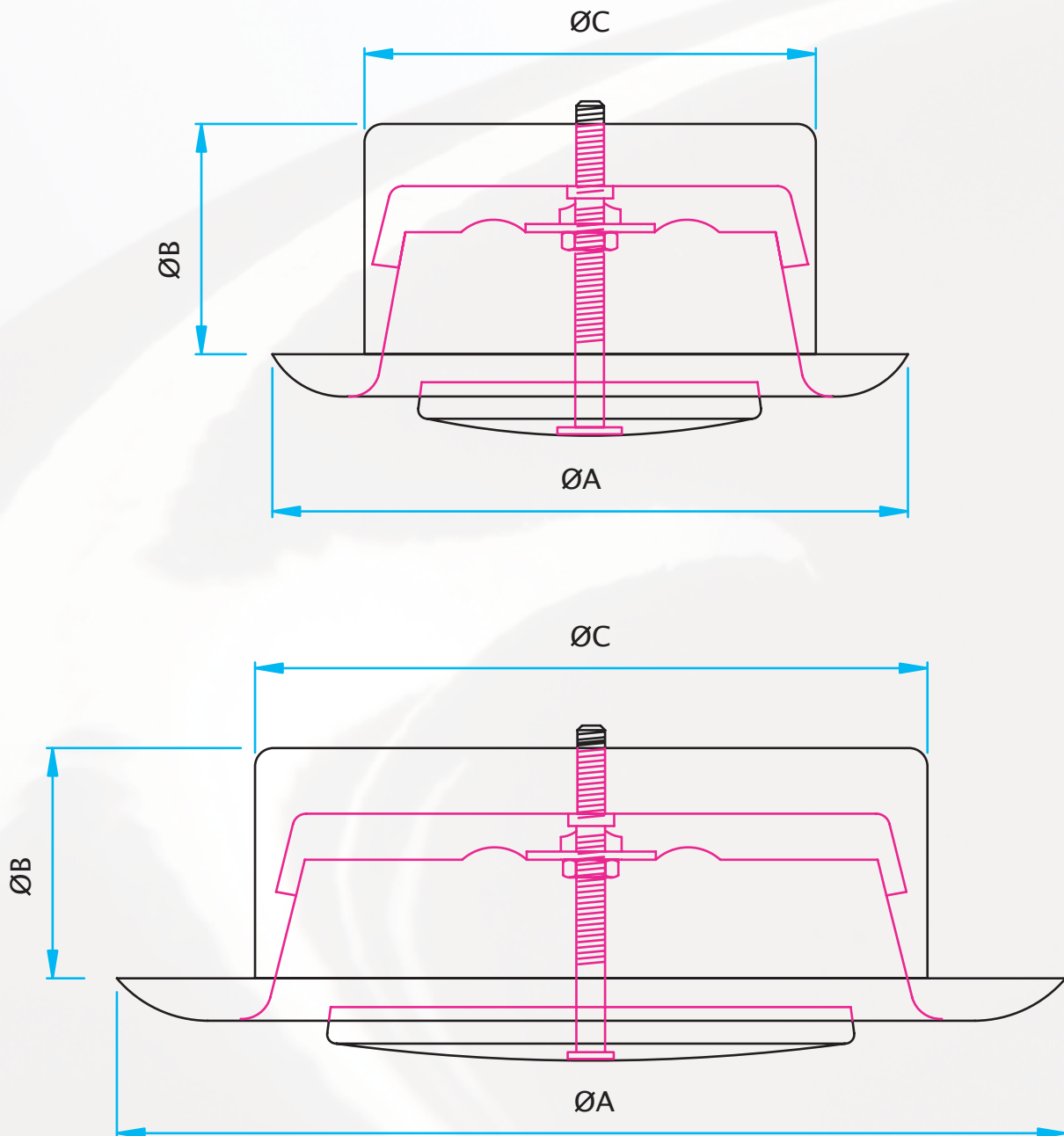

PRODUCT CODE	A	B	C	WEIGHT kg
HEV100	138	50	98	0.243
HEV125	166	50	123	0.305
HEV150	206	50	145	0.420
HEV200	250	50	196	0.604

Drawings

Dimensional Drawings

Supply Valves

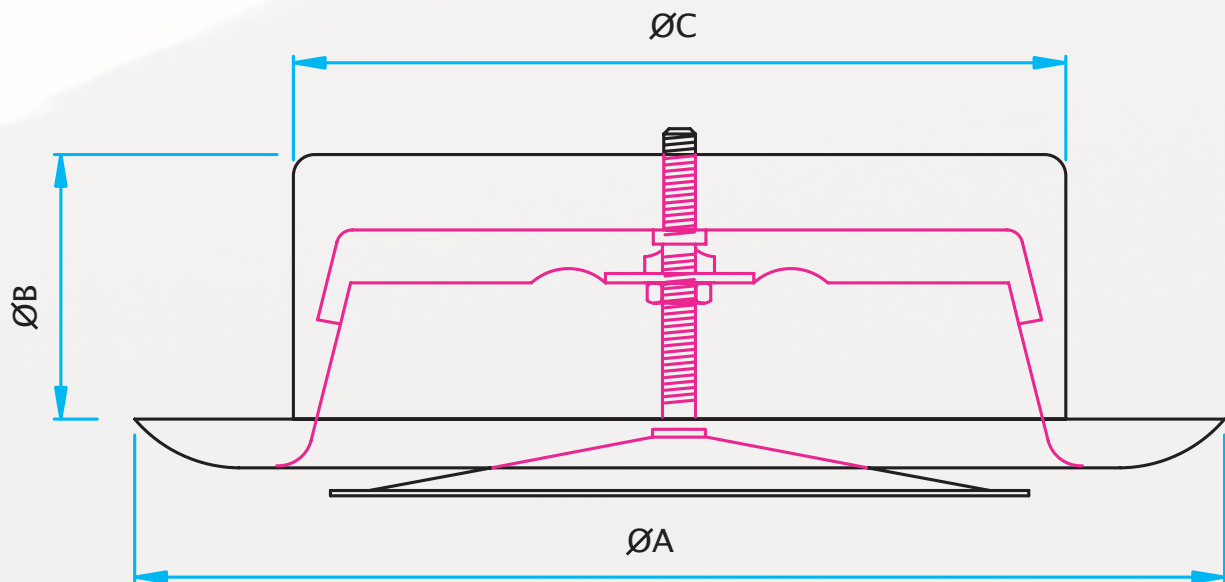
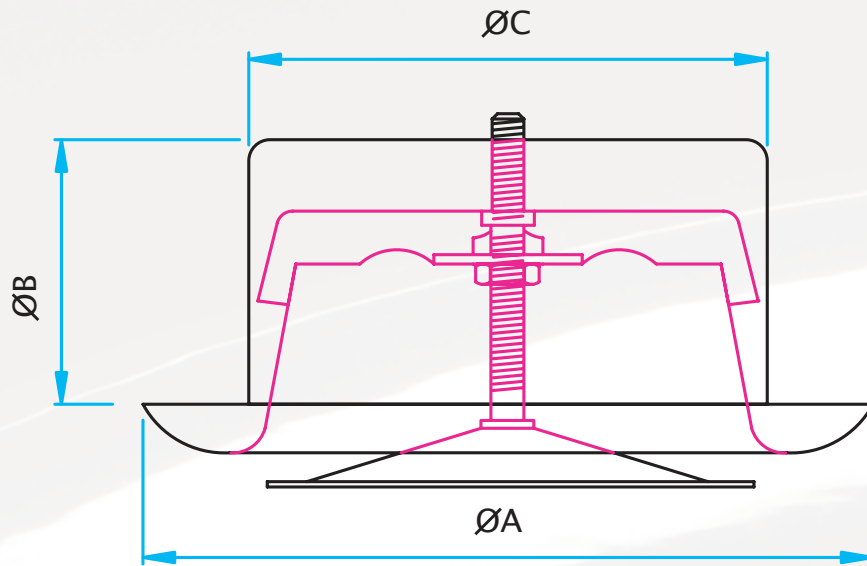

PRODUCT CODE	A	B	C	WEIGHT kg
HSV100	138	50	98	0.245
HSV125	166	50	123	0.306
HSV150	206	50	145	0.409
HSV200	250	50	196	0.606

Pressure Drop

HEV Extract Valve

HEV 100

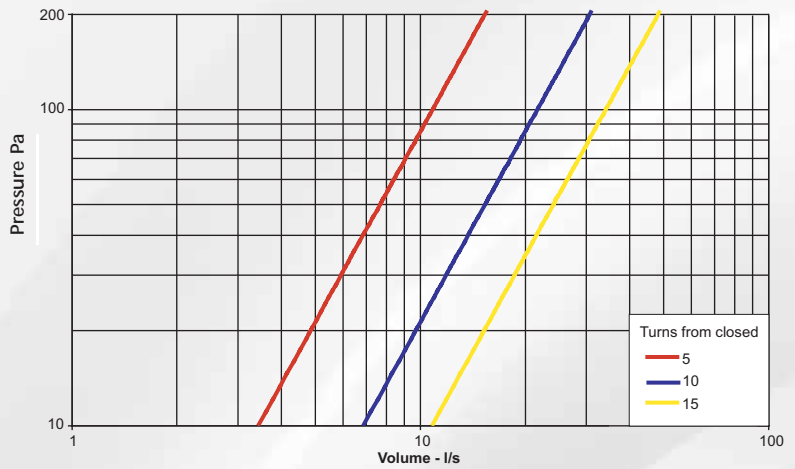

HEV 125

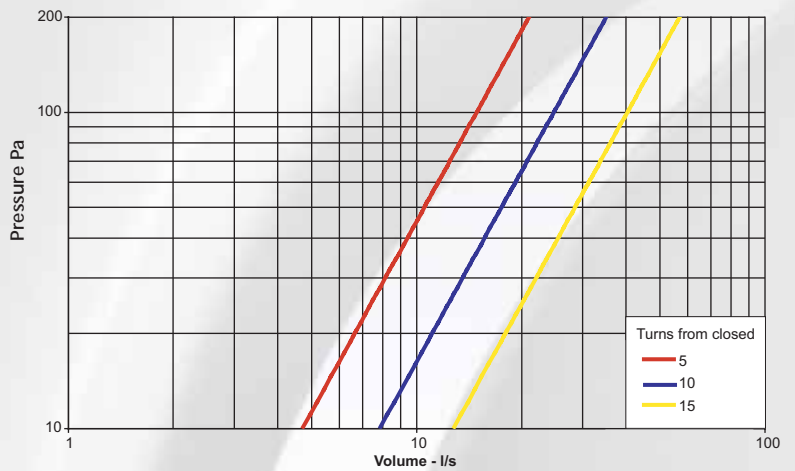

HEV 150

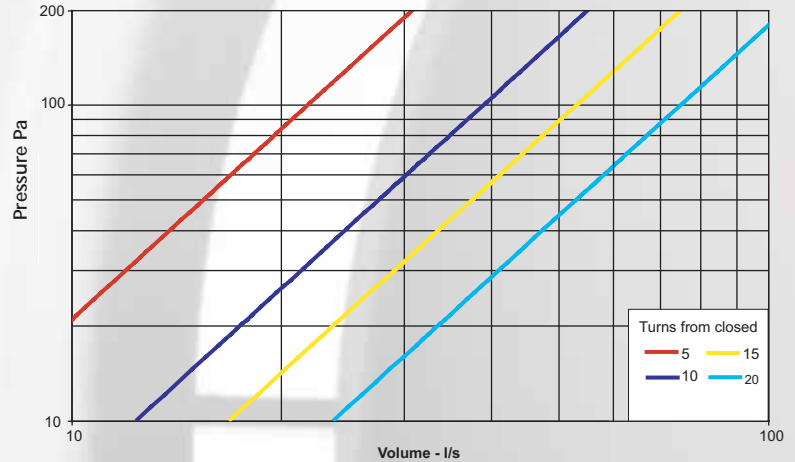

HEV 200

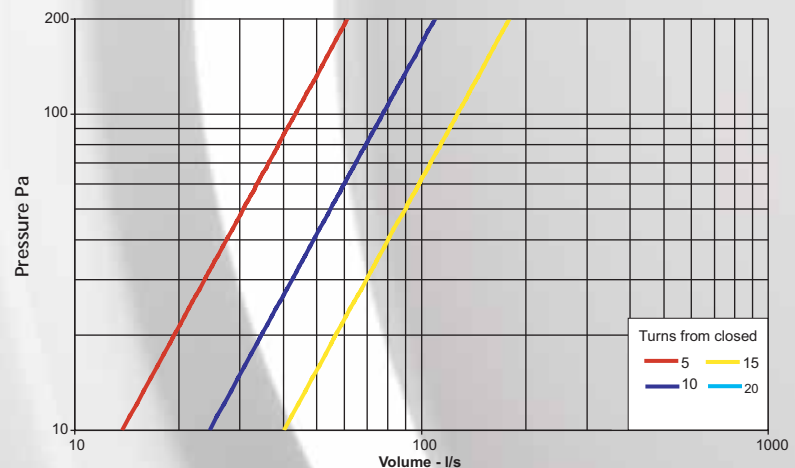

Pressure Drop

HSV Supply Valve

HSV 100

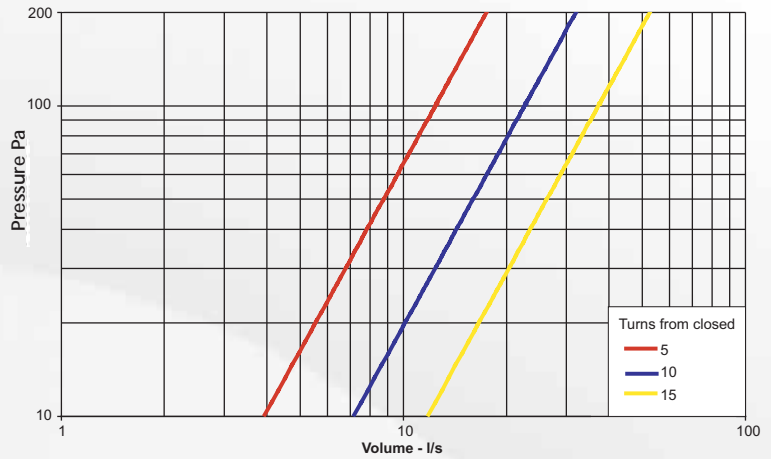

HSV 125

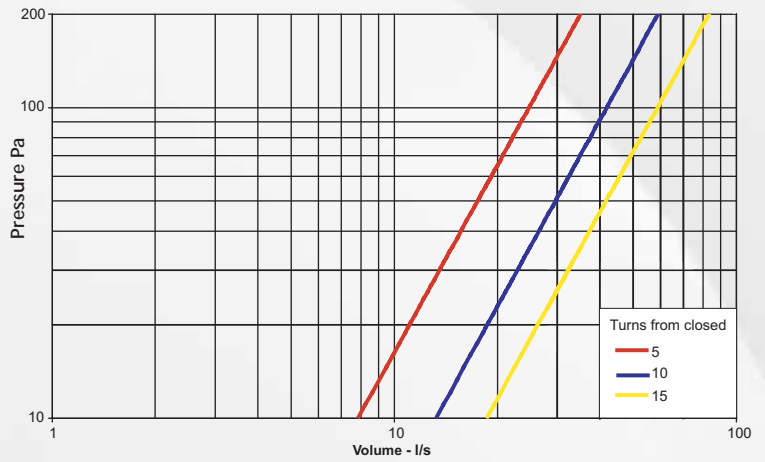

HSV 150

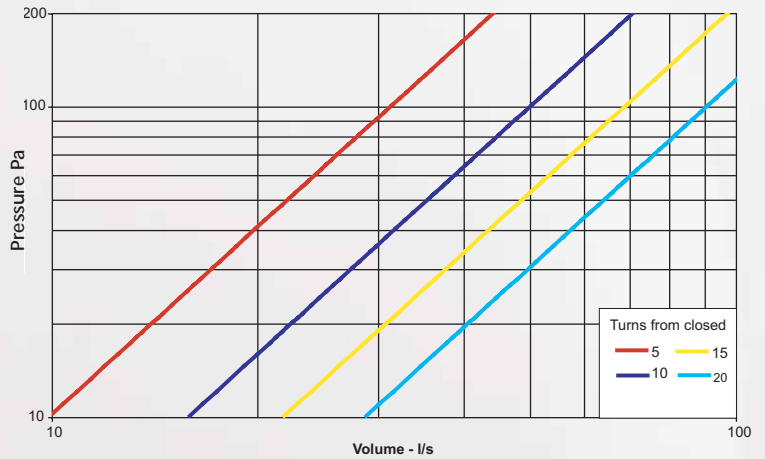

HSV 200

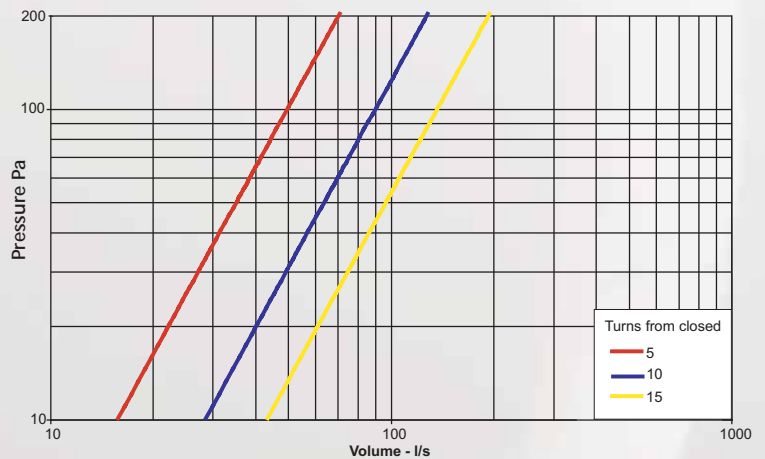



www.hydor.co.uk

Hydor Ltd · Unit 8 · Parkers Close · Downton Business Centre
Downton · Salisbury · Wiltshire · SP5 3RB
Tel: +44 (0) 1725 511422 · Fax: +44 (0) 1725 512637
e-mail: info@hydor.co.uk · www.hydor.co.uk

A division of Elta Group Ltd
HAV/15-02-07/01

FANS

CONTROLS

SYSTEMS