

HE Range

High Efficiency Propeller Fans



hydor

HE Fan Range

High Efficiency Propeller Fans



Features & Benefits

A modern high quality range of agricultural propeller fans designed to pass large volumes of air with minimum use of energy.

The HE Propeller fan produces air volumes of up to 4.84m³/s.

With a heavy duty construction, the HE fans principal benefit is the propeller shaped blades which scoop air and move it efficiently away from the fan. Blade tip clearance design enhances HE fan performance alongside large volume air movement.

Features & Benefits



- Quality robust construction incorporating stainless steel propeller.
- Available in 9 sizes 315/355/400/450/500/560/630/710/760.
- Very efficient power consumption.
- Reliable with high volume air movement.
- Extracts stale and humid air.
- Motors are particularly cool-running, constructed with a finned aluminium casing to give excellent heat dissipation.
- Two year (Conditional) extended warranty on all our motors.
- Optional EC conforming motor/propeller side guards.
- Motors are weatherproofed to IP55.
- Suitable for Form 'A' or Form 'B' operation.
- Ex-stock single phase and three phase fans.
- Can be suspended by chains at any angle or fitted into walls.
- Diaphragm mounted units without rings for special applications.
- Low noise level.
- Long service life.
- Quick and easy assembly.

Dimensional Data

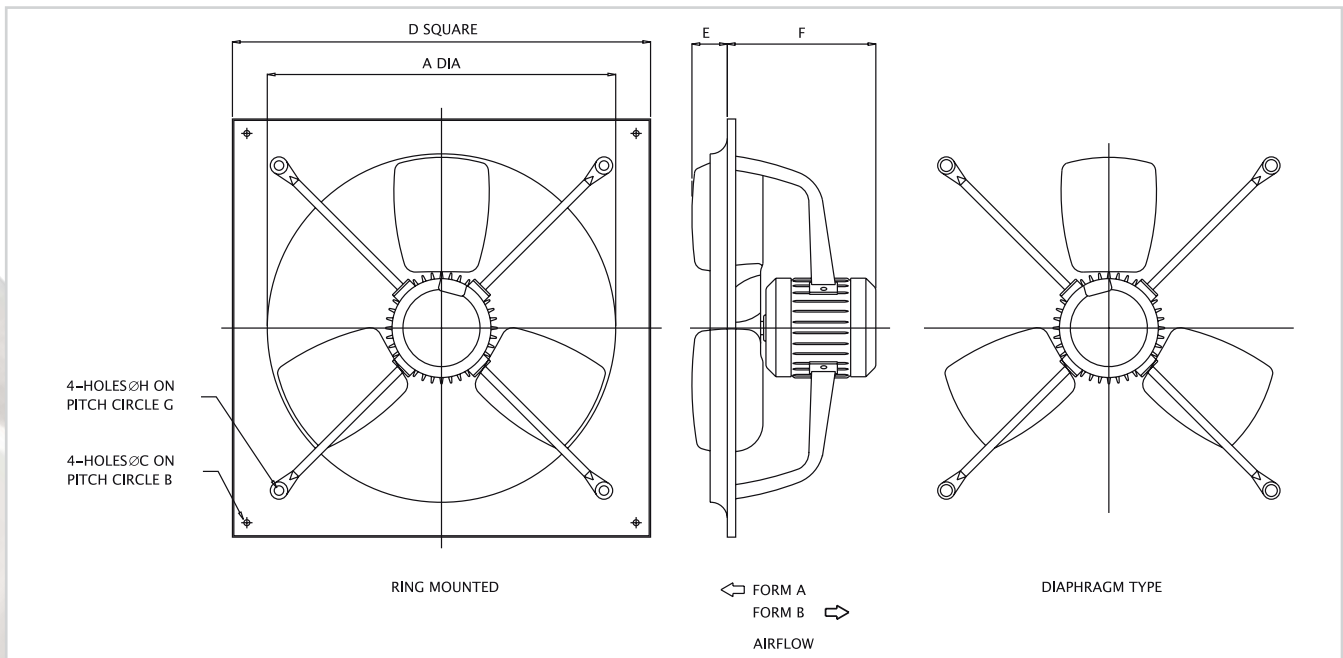

Fan Dia	A Aperture	B PCD	C Dia	D Sq	E	F Max	G PCD	H Dia	I Propeller	Weight (kg) HE R	Weight (kg) HE D
315	315	557	7	425	39	202	445	7	302	6.1	5.6
355	355	557	7	425	39	202	445	7	342	6.6	5.9
400	400	747	7	559	44	202	550	7	390	10	9.3
450	450	747	7	559	58	202	550	7	440	17	15
500	500	790	8.5	600	72	224	636	8.5	486	18	16
560	560	934	11	711	62	245	806	8.5	550	27	22
630	635	934	11	711	62	245	806	8.5	622	27	22
710	711	1024	11	800	62	245	905	8.5	700	29	23
760	782	1114	11	864	62	256	905	8.5	760	35	26

Performance & Electrical Data

Product Code	Airflow m ³ /s @ Static Pressure Pa.					Speed (r/min)	Motor Electrical Data				Sound Level dBA @ 3m
	0	25	50	75	100		Power Watts	FL Amps	Start Amps	Capacitor uF	
HE315/4-1	0.567	0.517	0.403	0.192	-	1350	55	1.3	3.8	3	50
HE315/6-1	0.378	0.236	-	-	-	900	20	0.4	0.6	2	39
HE355/4-1	0.861	0.799	0.700	0.558	0.354	1350	120	1.35	4.0	8	56
HE355/6-1	0.558	0.408	-	-	-	900	40	0.7	1.8	4	43
HE400/4-1	1.250	1.142	1.022	0.879	0.518	1350	180	1.45	4.0	8	57
HE400/6-1	0.819	0.671	0.281	-	-	900	70	0.8	1.9	4	45
HE450/4-1	1.692	1.572	1.422	1.267	1.021	1350	280	1.9	4.0	8	60
HE450/6-1	1.103	0.971	0.494	-	-	900	80	1.0	2.1	4	49
HE500/4-1	2.411	2.350	2.261	2.131	1.981	1350	500	3.0	6.0	10	62
HE500/6-1	1.600	1.519	1.250	0.681	-	900	190	1.5	3.4	6	50
HE560/6-1	2.142	2.072	1.811	0.750	-	900	250	1.8	4.5	8	58
HE630/6-1	3.303	3.111	2.944	2.742	2.181	900	390	2.9	7.6	14	60
HE710/6-1	4.242	4.100	3.944	3.731	3.306	900	550	3.7	7.6	16	61
HE760/6-1	4.847	4.672	4.481	4.261	3.942	900	670	5.3	12.0	28	63

Product Code	Airflow m ³ /s @ Static Pressure Pa.					Speed (r/min)	Motor Electrical Data			Sound Level dBA @ 3m
	0	25	50	75	100		Power Watts	FL Amps	Start Amps	
HE450/4-3	1.692	1.572	1.422	1.267	1.021	1350	280	1.0	4.0	60
HE450/6-3	1.103	0.971	0.494	-	-	900	80	0.6	1.9	49
HE500/4-3	2.411	2.350	2.261	2.131	1.981	1350	500	1.2	4.4	62
HE500/6-3	1.600	1.519	1.250	0.681	-	900	190	0.9	2.3	50
HE560/4-3	3.353	3.250	3.131	3.011	2.872	1350	750	1.8	4.5	70
HE560/6-3	2.142	2.072	1.811	0.750	-	900	250	1.0	3.5	58
HE630/6-3	3.303	3.111	2.944	2.742	2.181	940	390	1.5	3.6	60
HE710/6-3	4.242	4.100	3.944	3.731	3.306	900	550	1.7	4.0	61
HE760/6-3	4.847	4.672	4.481	4.261	3.942	900	670	2.2	5.0	63

Acoustic data: tests and preparation of data have been carried out in accordance with BS848 part 2 (1985). The sound pressure level is at a distance of three metres with spherical propagation. It is expressed in dB re 20uPa. The values are presented for comparative purposes only as in practice the semi-reverberant nature of any installation and directivity effects can give a different level.

Air data: All units are tested to ISO 5801:1997. As with any fan unit, the actual performance depends on proper mounting, please ask for assistance if you are unsure what unit you require for your application.

Accessories



- Motor or Propeller side wire guards to BS848 Part 2 finished in red powder coat to RAL7031.
- Air Operated louvre shutters available in Aluminium / Alu-Zinc and plastic.
- Two speed switch for added precision, flexibility, control and regulation of energy consumption.
- A single fan, manual speed regulator (VMRD1) with overload protection - models available for up to six fans.

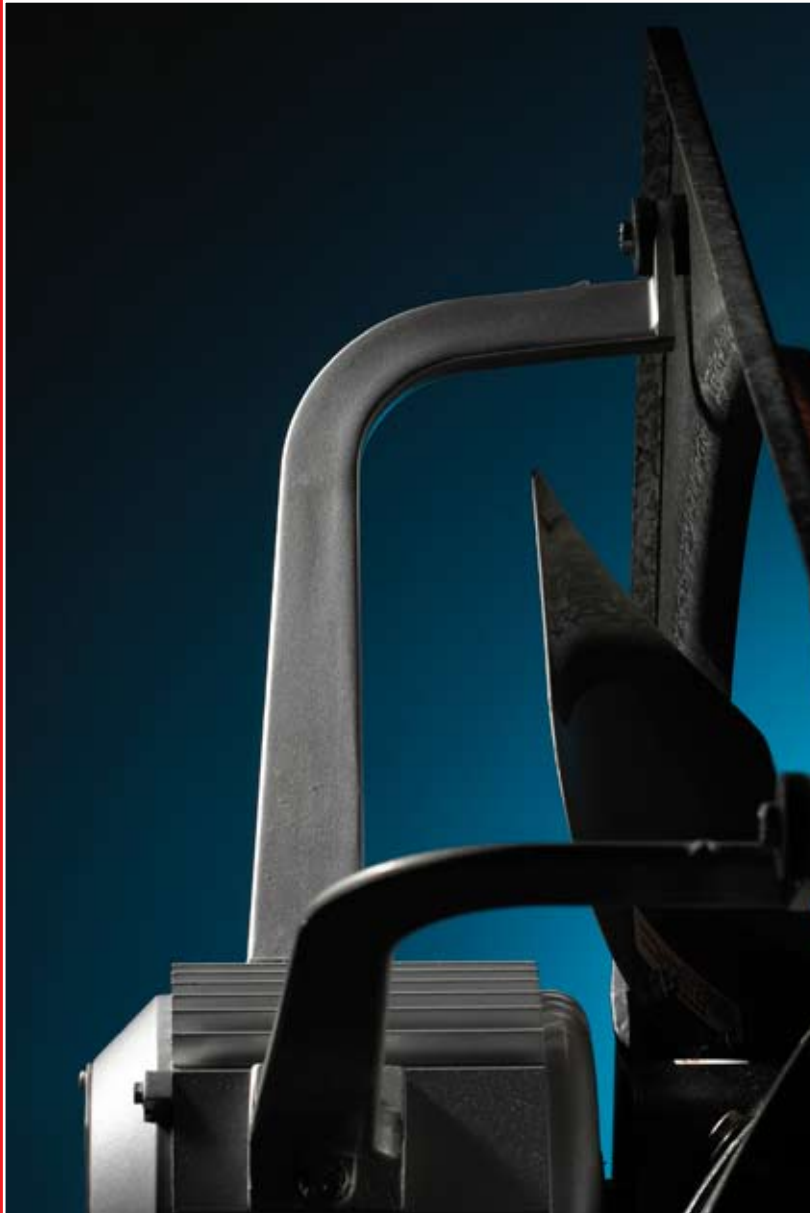

www.hydor.co.uk

Hydor Ltd · Unit 8 · Parkers Close · Downton Business Centre
Downton · Salisbury · Wiltshire · SP5 3RB
Tel: +44 (0) 1725 511422 · Fax: +44 (0) 1725 512637
e-mail: info@hydor.co.uk · www.hydor.co.uk

HE_EB/21-04-10/01

A member of the



FANS

CONTROLS

SYSTEMS