

# In-Line Duct Fans

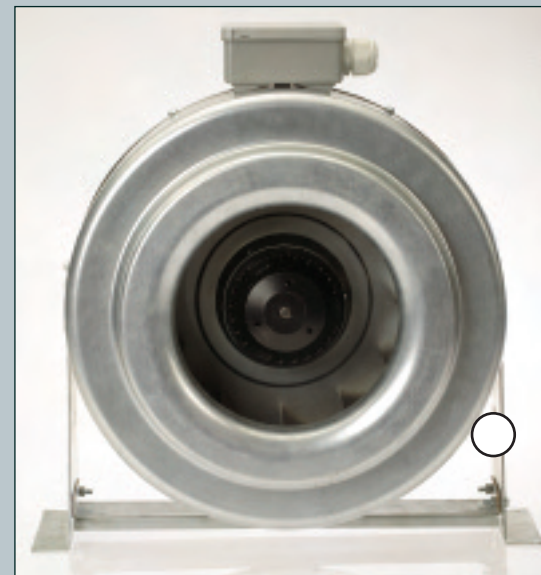

hydor



## Introduction

The Hydor HIT range of all metal in-line centrifugal fans are principally designed for duct mounted applications, with seven standard sizes from 100mm to 315mm diameter, performance up to 0.51 m<sup>3</sup>/s and static pressures of up to 650 Pa. They provide the ideal solution for high performance requirements in low airflow, medium pressure systems.

## Features

- 7 standard sizes from 100mm to 315mm.
- Air volume flow rates of up to 0.51 m/sec.
- Static pressures of up to 650 Pa.
- Motors are external rotor, to IP44 with Class F Insulation.
- Single inlet backward curved centrifugal impellers.
- Suitable for ambient operating temperatures of up to +50° C.
- Easy to install.
- Air guide vanes.
- Thermal overload protection.
- Three speed motor.
- Fans can be mounted at any angle.
- Mounting brackets included.
- Fully speed controllable.
- IP54 rated terminal box.
- Robust steel casing.
- Extensive range of stock is available.

# ngge

## Benefits

### Range

An extensive range of nine sizes from 100mm to 315mm diameter, which means greater performance choice.

### Ease of installation

All models are designed for direct connection to standard diameter flexible or rigid circular ducting with 25mm long spigots for ease of connection.

### Casing

Each unit has a heavy gauge pressed steel housing, which is durable, long lasting and corrosion resistant.

### Guide Vanes

The integral guide vanes are designed to provide a smoother airflow by straightening the air and reducing noise turbulence.

### Easy assembly

The integral mounting bracket provides a fast, simple approach to fixing the fan in position.

### Flexibility

A three speed backward curved centrifugal impeller increases the flexibility by allowing the desired speed setting to be selected either at the time of installation, or by an optional remote mounted three speed switch for high, medium and low settings.

### Reliability

Motors have sealed for life bearings.

### Motor protection

All HIT units have integral thermal overload protection which prevents the motor from overheating.

### Assurance

Non self-resetting thermal cut outs are fitted in accordance with EN60335-2-80. The thermal cut-out switches the fan off in the event of a fault condition and will require the power being turned off, then back on again to reset.

### Ease of wiring

Connections are made via an IP54 rated terminal box which is fitted onto the outside of the unit casing.

### Quality impellers

A high efficiency, single inlet, single width backward curved centrifugal impeller which is designed to be non overloading and self cleaning.

### Tested to the very latest standards

HIT units are tested to ISO 5801:1997 (airside performance) and to BS 848 Pt 2:1985 (sound performance) at Elta Fans own test facility, meaning accurate, up to date information on performance and noise data that can be relied upon.

### Warranty

Each HIT has a 12 month warranty.

### Full ancillary range

Speed controllers, fast clamps, electric heater batteries, silencers, panel filters, flexible connectors, backdraught dampers, extract and supply valves.

## Applications

HIT fans can be used for a wide variety of industrial, light commercial & domestic applications from showers, cafeteria's, toilets, entrance halls to duct ventilation boost, bathrooms, equipment cooling, air curtain supply, restaurants and many other applications.



# Specification

## General

The HIT range of in-line centrifugal duct fans as manufactured by Hydor Ltd, Unit 8, Parkers Close, Downton Business Centre, Downton, Nr Salisbury, Wiltshire, SP5 3RB. Tel: +44 (0) 1725 511422 or visit [www.hydor.co.uk](http://www.hydor.co.uk).

## Casing

Hydor HIT casings have a galvanised pressed sheet steel construction, providing a robust, long lasting and corrosion resistant casing.

The inlet and outlet spigots should be a minimum 25mm long to enable the installation and fixing to circular rigid or flexible ductwork.

## Mounting Brackets

All HIT units are to be supplied complete with integral mounting brackets manufactured from galvanised sheet steel for horizontal or vertical mounting arrangements.

## Impellers

All impellers are single inlet backward curved centrifugal type.

## Motors

All motors are to be highly efficient, three speed external rotor motors, matched to the aerodynamic performance of the impeller.

Motors have sealed for life ball bearings to enable the fan to be mounted at any angle.

Motors are protected to IP44 with Class F insulation, suitable for speed control and ambient operating temperatures of up to +50°C with built in thermal overload protection.

Non self-resetting thermal cut-outs are fitted in accordance with EN60335-2-80.

Motors are wound for 230V/1Ph/50/60Hz supply.

Electrical connections are made by an IP54 terminal box fitted to the outside of the fan casing.



# Performance Data & Performance Curves

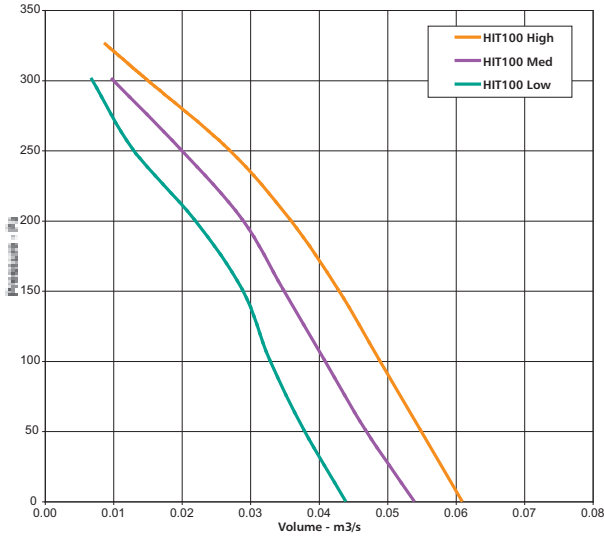

All performance, sound and electrical data is stated at 230V 50Hz. For 60Hz data contact Hydror.

## HIT100 PERFORMANCE

PRODUCT CODE	m³/s @ Pa							
	0	50	100	150	200	250	300	350
HIT100 HIGH	0.061	0.055	0.049	0.043	0.036	0.027	0.015	0.009
HIT100 MED	0.054	0.047	0.041	0.035	0.029	0.020	0.010	
HIT100 LOW	0.044	0.038	0.033	0.029	0.022	0.013	0.007	

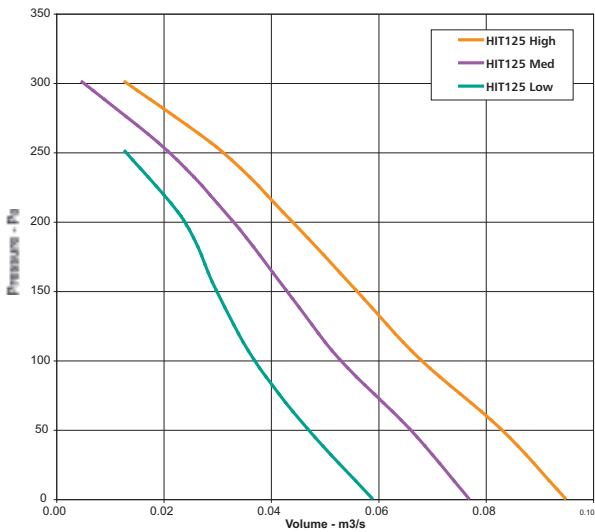

## HIT125 PERFORMANCE

PRODUCT CODE	m³/s @ Pa						
	0	50	100	150	200	250	300
HIT125 HIGH	0.095	0.083	0.068	0.056	0.044	0.031	0.013
HIT125 MED	0.077	0.066	0.053	0.043	0.033	0.021	0.005
HIT125 LOW	0.059	0.047	0.037	0.030	0.024	0.013	

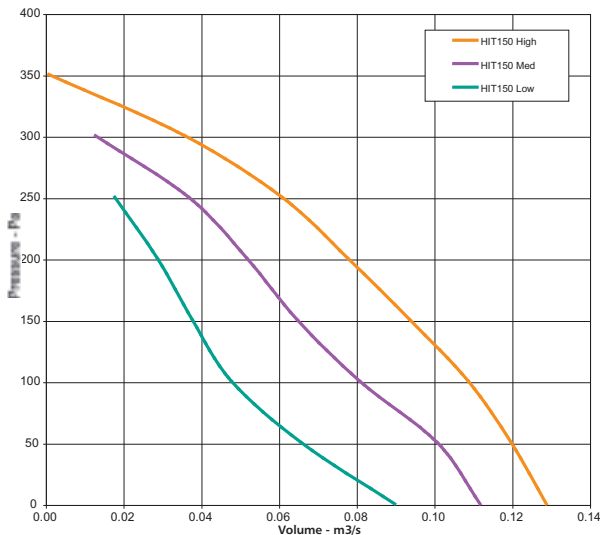

## HIT150 PERFORMANCE

PRODUCT CODE	m³/s @ Pa							
	0	50	100	150	200	250	300	350
HIT150 HIGH	0.129	0.120	0.109	0.094	0.078	0.061	0.036	0.001
HIT150 MED	0.112	0.101	0.081	0.065	0.052	0.037	0.013	
HIT150 LOW	0.090	0.066	0.048	0.038	0.029	0.018		

# Performance Data & Curves

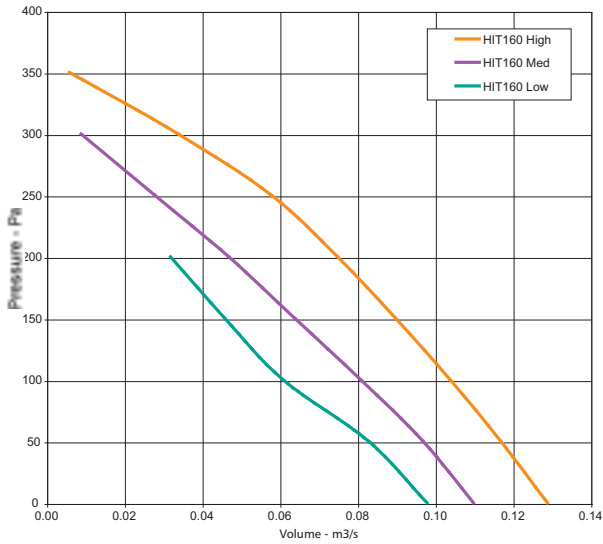

## HIT160 PERFORMANCE

CODE	m³/s @ Pa							
	0	50	100	150	200	250	300	350
HIT160 HIGH	0.129	0.117	0.104	0.090	0.075	0.058	0.034	0.006
HIT160 MED	0.110	0.097	0.081	0.064	0.047	0.028	0.009	
HIT160 LOW	0.098	0.083	0.061	0.046	0.032			

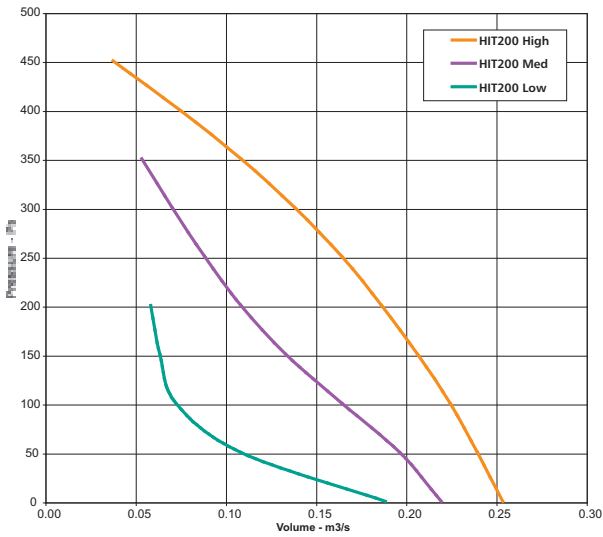

## HIT200 PERFORMANCE

CODE	m³/s @ Pa									
	0	50	100	150	200	250	300	350	400	450
HIT200 HIGH	0.254	0.240	0.225	0.207	0.187	0.165	0.139	0.109	0.075	0.038
HIT200 MED	0.220	0.197	0.165	0.134	0.109	0.089	0.071	0.054		
HIT200 LOW	0.189	0.109	0.073	0.064	0.059					

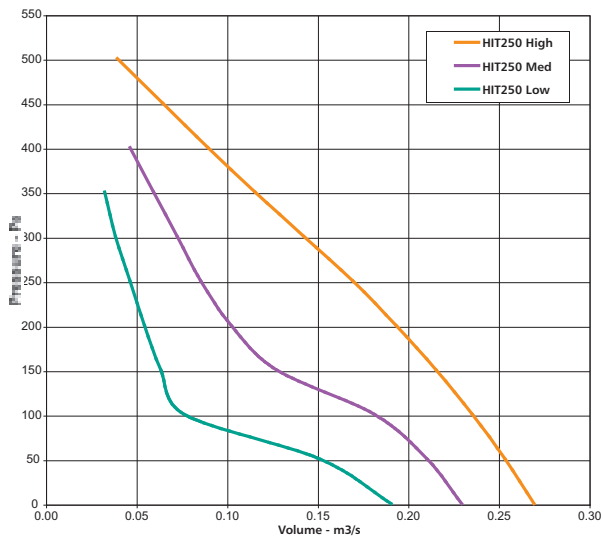

## HIT250 PERFORMANCE

PRODUCT CODE	m³/s @ Pa											
	0	50	100	150	200	250	300	350	400	450	500	
HIT250 HIGH	0.270	0.254	0.236	0.216	0.194	0.170	0.143	0.116	0.090	0.065	0.040	
HIT250 MED	0.230	0.211	0.182	0.128	0.103	0.086	0.073	0.060	0.047			
HIT250 LOW	0.191	0.152	0.077	0.064	0.055	0.047	0.039	0.033				

# Data & Curves

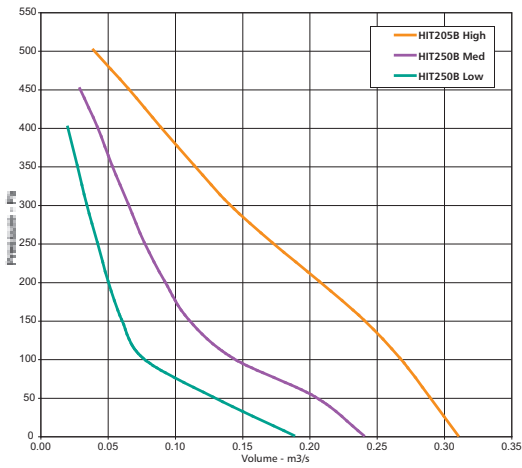

## HIT250B PERFORMANCE

PRODUCT CODE

	m³/s @ Pa										
	0	50	100	150	200	250	300	350	400	450	500
<b>HIT250B HIGH</b>	0.311	0.290	0.268	0.241	0.208	0.173	0.141	0.115	0.090	0.066	0.040
<b>HIT250B MED</b>	0.241	0.205	0.144	0.111	0.093	0.078	0.066	0.054	0.043	0.030	
<b>HIT250B LOW</b>	0.189	0.129	0.077	0.061	0.051	0.043	0.035	0.028	0.021		

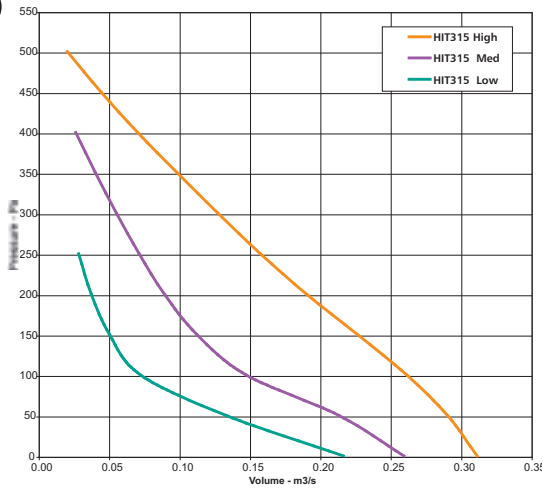

## HIT315 PERFORMANCE

PRODUCT CODE

	m³/s @ Pa										
	0	50	100	150	200	250	300	350	400	450	500
<b>HIT315 HIGH</b>	0.312	0.291	0.262	0.227	0.191	0.158	0.128	0.099	0.071	0.045	0.021
<b>HIT315 MED</b>	0.260	0.214	0.148	0.113	0.090	0.072	0.056	0.041	0.027		
<b>HIT315 LOW</b>	0.217	0.134	0.073	0.051	0.038	0.029					

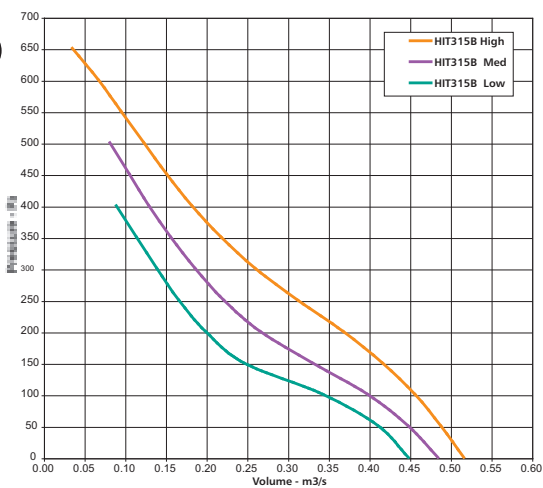

## HIT315B PERFORMANCE

PRODUCT CODE

	m³/s @ Pa													
	0	50	100	150	200	250	300	350	400	450	500	550	600	650
<b>HIT315B HIGH</b>	0.517	0.489	0.457	0.417	0.369	0.313	0.261	0.219	0.183	0.152	0.124	0.096	0.068	0.036
<b>HIT315B MED</b>	0.485	0.449	0.399	0.331	0.267	0.222	0.187	0.157	0.130	0.106	0.082			
<b>HIT315B LOW</b>	0.449	0.412	0.344	0.247	0.200	0.167	0.140	0.115	0.090					

# Sound Data



HIT 100 SOUND POWER LEVEL SPECTRA

Product Code		Octave Band								dBa
		63 Hz	125 Hz	250 Hz	500 Hz	1 kHz	2 kHz	4 kHz	8 kHz	@3m
HIT100 High	Inlet	57	60	67	63	63	59	52	47	46
	Outlet	61	62	64	61	63	58	53	47	46
	Breakout	69	59	58	57	57	49	44	39	39
HIT100 Med	Inlet	54	58	64	61	61	57	50	45	44
	Outlet	59	61	62	59	61	57	51	45	43
	Breakout	57	57	57	55	55	48	44	40	38
HIT100 Low	Inlet	56	56	62	59	59	54	47	42	42
	Outlet	59	59	60	57	60	55	49	42	42
	Breakout	55	56	56	55	54	46	42	34	37

HIT 125 SOUND POWER LEVEL SPECTRA

Product Code		Octave Band								dBa
		63 Hz	125 Hz	250 Hz	500 Hz	1 kHz	2 kHz	4 kHz	8 kHz	@3m
HIT125 High	Inlet	60	60	66	63	63	60	55	48	47
	Outlet	61	62	66	66	66	62	57	50	49
	Breakout	57	58	59	62	60	53	45	37	43
HIT125 Med	Inlet	57	58	63	60	60	57	51	43	43
	Outlet	61	59	63	63	63	59	53	45	46
	Breakout	56	56	58	59	57	50	42	33	40
HIT125 Low	Inlet	56	54	57	55	54	51	46	43	37
	Outlet	59	56	59	59	59	54	47	38	42
	Breakout	55	53	54	56	53	46	38	30	36

HIT 150 SOUND POWER LEVEL SPECTRA

Product Code		Octave Band								dBa
		63 Hz	125 Hz	250 Hz	500 Hz	1 kHz	2 kHz	4 kHz	8 kHz	@3m
HIT150 High	Inlet	60	60	66	63	63	60	55	48	47
	Outlet	61	62	68	65	66	61	55	48	49
	Breakout	59	61	62	62	59	53	48	36	43
HIT150 Med	Inlet	57	58	63	60	60	57	51	43	43
	Outlet	58	60	64	62	62	56	49	41	45
	Breakout	57	58	59	59	56	48	37	28	39
HIT150 Low	Inlet	56	54	57	55	54	51	46	43	37
	Outlet	55	57	58	56	56	50	40	32	39
	Breakout	55	54	55	54	51	44	36	28	35

HIT 160 SOUND POWER LEVEL SPECTRA

Product Code		Octave Band								dBa
		63 Hz	125 Hz	250 Hz	500 Hz	1 kHz	2 kHz	4 kHz	8 kHz	@3m
HIT160 High	Inlet	60	60	66	63	63	60	55	48	47
	Outlet	61	62	68	65	66	61	55	48	49
	Breakout	59	61	62	62	59	53	48	36	43
HIT160 Med	Inlet	57	58	63	60	60	57	51	43	43
	Outlet	58	60	64	62	62	56	49	41	45
	Breakout	57	58	59	59	56	48	37	28	39
HIT160 Low	Inlet	56	54	57	55	54	51	46	43	37
	Outlet	55	57	58	56	56	50	40	32	39
	Breakout	55	54	55	54	51	44	36	28	35

HIT 200 SOUND POWER LEVEL SPECTRA

Product Code		Octave Band								dBa
		63 Hz	125 Hz	250 Hz	500 Hz	1 kHz	2 kHz	4 kHz	8 kHz	@3m
HIT200 High	Inlet	59	64	69	67	67	66	60	55	51
	Outlet	64	66	73	70	68	66	60	54	53
	Breakout	60	64	69	65	62	59	52	40	47
HIT200 Med	Inlet	57	66	66	63	63	61	55	48	47
	Outlet	59	64	71	65	63	61	54	45	48
	Breakout	59	63	65	61	58	54	44	32	42
HIT200 Low	Inlet	56	61	63	58	58	56	46	37	42
	Outlet	55	60	60	59	57	53	44	33	41
	Breakout	63	66	62	62	58	52	40	32	42

Product Code		Octave Band								dBA
		63 Hz	125 Hz	250 Hz	500 Hz	1 kHz	2 kHz	4 kHz	8 kHz	@3m
HIT250 High	Inlet	64	65	70	70	68	65	62	58	52
	Outlet	65	69	72	74	73	69	64	57	56
	Breakout	64	67	65	69	66	61	52	41	50
HIT250 Med	Inlet	63	64	67	66	65	61	59	53	48
	Outlet	63	69	69	71	68	65	59	52	52
	Breakout	62	67	62	65	61	56	46	34	45
HIT250 Low	Inlet	62	66	64	62	60	56	55	42	44
	Outlet	60	71	66	65	62	59	52	41	46
	Breakout	59	69	58	60	54	50	41	37	40

HIT 250 SOUND POWER  
LEVEL SPECTRA

Product Code		Octave Band								dBA
		63 Hz	125 Hz	250 Hz	500 Hz	1 kHz	2 kHz	4 kHz	8 kHz	@3m
HIT250B High	Inlet	65	64	65	68	68	65	63	55	52
	Outlet	66	68	71	77	71	68	63	56	56
	Breakout	62	65	62	67	63	58	49	37	47
HIT250B Med	Inlet	60	68	62	63	63	61	55	43	46
	Outlet	63	66	72	68	64	62	54	44	49
	Breakout	59	70	60	60	56	52	40	28	41
HIT200B Low	Inlet	59	61	58	57	58	55	45	35	41
	Outlet	58	60	63	60	58	56	45	36	42
	Breakout	49	52	49	54	50	45	36	24	34

HIT 250B SOUND POWER  
LEVEL SPECTRA

Product Code		Octave Band								dBA
		63 Hz	125 Hz	250 Hz	500 Hz	1 kHz	2 kHz	4 kHz	8 kHz	@3m
HIT315 High	Inlet	69	67	67	74	72	66	66	63	56
	Outlet	69	67	71	75	71	70	65	62	56
	Breakout	64	67	61	68	65	59	50	41	48
HIT315 Med	Inlet	65	63	64	68	67	63	61	58	50
	Outlet	65	66	68	70	66	65	61	57	51
	Breakout	60	62	62	60	57	52	43	36	41
HIT315 Low	Inlet	63	62	64	61	63	60	57	48	46
	Outlet	62	62	68	64	61	61	57	51	47
	Breakout	57	60	57	54	53	47	40	27	36

HIT 315 SOUND POWER  
LEVEL SPECTRA

Product Code		Octave Band								dBA
		63 Hz	125 Hz	250 Hz	500 Hz	1 kHz	2 kHz	4 kHz	8 kHz	@3m
HIT315B High	Inlet	69	70	68	74	71	69	65	65	56
	Outlet	73	71	71	74	73	73	67	67	58
	Breakout	68	73	62	64	61	58	48	41	46
HIT315B Med	Inlet	68	76	67	71	69	67	64	64	53
	Outlet	70	74	70	72	71	71	65	66	56
	Breakout	66	75	62	66	63	60	50	43	47
HIT315B Low	Inlet	67	75	66	68	67	66	61	62	51
	Outlet	70	74	69	70	68	69	63	64	53
	Breakout	66	72	63	68	66	62	53	45	50

HIT 315B SOUND POWER  
LEVEL SPECTRA

## Silencer Insertion Loss

Product Code	Attenuation dB mid Frequency Hz							
	63	125	250	500	1k	2k	4k	8k
HCS100-1	3	4	9	17	23	26	25	14
HCS125-1	3	3	8	16	21	24	22	12
HCS150-1	3	3	6	14	19	23	22	11
HCS160-1	3	3	6	14	19	23	22	11
HCS200-1	2	3	6	13	17	20	18	9
HCS250-1	2	3	6	12	16	19	17	8
HCS315-1	1	3	6	12	15	18	16	8
HCS100-2	5	8	15	33	39	40	36	20
HCS125-2	4	8	13	30	35	35	31	15
HCS150-2	4	7	12	23	30	36	31	15
HCS160-2	4	7	12	23	29	35	30	15
HCS200-2	4	6	10	20	27	32	20	11
HCS250-2	3	6	10	19	25	29	18	10
HCS315-2	3	5	8	16	21	22	16	14

Product Code	Attenuation dB mid Frequency Hz							
	63	125	250	500	1k	2k	4k	8k
HCS100-3	10	13	21	40	45	40	36	24
HCS125-3	9	12	18	37	41	38	34	20
HCS150-3	8	9	15	31	37	37	34	18
HCS160-3	8	9	15	31	37	37	34	18
HCS200-3	7	9	14	32	39	36	26	15
HCS250-3	5	8	12	24	30	30	22	14
HCS315-3	4	7	10	20	31	28	17	14
HCS100-4	12	15	23	42	47	42	38	26
HCS125-4	11	15	21	40	46	41	36	23
HCS150-4	10	14	17	34	41	40	36	20
HCS160-4	10	14	18	33	40	39	35	18
HCS200-4	10	12	17	35	41	44	28	16
HCS250-4	7	10	15	31	37	38	26	15
HCS315-4	6	9	14	23	32	32	18	15

# Electrical Data



HIT 100		Speed r/min	FLC Amps	SC Amps	Power W	Electronic Controller	Transformer Controller	Weight kg	3-Speed Switch
	HIT100 High	2641	0.26	0.9	59	HFC1.7	TC12	3.7	HFT1.7
HIT100 Med	2339	0.22	0.8	48					
HIT100 Low	1983	0.22	0.8	48					

HIT 125		Speed r/min	FLC Amps	SC Amps	Power W	Electronic Controller	Transformer Controller	Weight kg	3-Speed Switch
	HIT125 High	2550	0.27	0.95	64	HFC1.7	TC12	3.7	HFT1.7
HIT125 Med	2167	0.24	0.84	51					
HIT125 Low	1715	0.23	0.81	50					

HIT 150		Speed r/min	FLC Amps	SC Amps	Power W	Electronic Controller	Transformer Controller	Weight kg	3-Speed Switch
	HIT150 High	2578	0.26	0.9	62	HFC1.7	TC12	3.6	HFT1.7
HIT150 Med	2215	0.23	0.8	52					
HIT150 Low	1800	0.22	0.8	50					

HIT 160		Speed r/min	FLC Amps	SC Amps	Power W	Electronic Controller	Transformer Controller	Weight kg	3-Speed Switch
	HIT160 High	2585	0.26	0.9	61	HFC1.7	TC12	3.6	HFT1.7
HIT160 Med	2265	0.23	0.8	49					
HIT160 Low	1832	0.22	0.8	48					

HIT 200		Speed r/min	FLC Amps	SC Amps	Power W	Electronic Controller	Transformer Controller	Weight kg	3-Speed Switch
	HIT200 High	2502	0.66	2.3	155	HFC1.7	TC12	5.5	HFT1.7
HIT200 Med	2083	0.60	2.1	137					
HIT200 Low	1670	0.57	2.0	129					

HIT 250		Speed r/min	FLC Amps	SC Amps	Power W	Electronic Controller	Transformer Controller	Weight kg	3-Speed Switch
	HIT250 High	2520	0.65	2.3	151	HFC1.7	TC12	5.3	HFT1.7
HIT250 Med	2121	0.59	2.1	133					
HIT250 Low	1720	0.56	2.0	128					

HIT 250B		Speed r/min	FLC Amps	SC Amps	Power W	Electronic Controller	Transformer Controller	Weight kg	3-Speed Switch
	HIT250B High	2480	0.68	2.4	158	HFC1.7	TC12	5.3	HFT1.7
HIT250B Med	2000	0.62	2.2	143					
HIT250B Low	1150	0.59	2.1	134					

HIT 315		Speed r/min	FLC Amps	SC Amps	Power W	Electronic Controller	Transformer Controller	Weight kg	3-Speed Switch
	HIT315 High	2528	0.68	2.4	156	HFC1.7	TC12	8.1	HFT1.7
HIT315 Med	2130	0.60	2.1	139					
HIT315 Low	1770	0.58	2.0	132					

HIT 315B		Speed r/min	FLC Amps	SC Amps	Power W	Electronic Controller	Transformer Controller	Weight kg	3-Speed Switch
	HIT315B High	2480	1.02	3.6	234	HFC1.7	TC12	8.8	HFT1.7
HIT315B Med	2300	0.96	3.4	215					
HIT315B Low	2130	0.94	3.3	208					

# Wiring Diagram

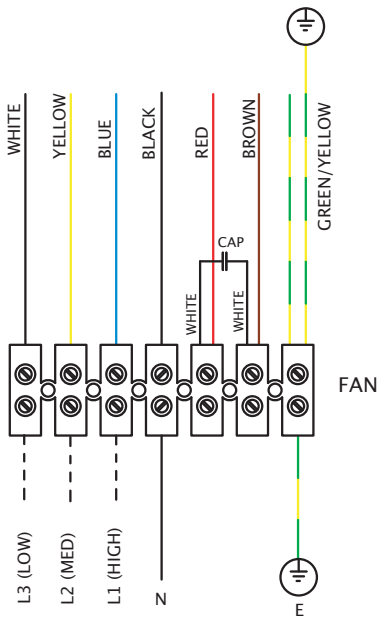

230V 1Ph 50 Hz SUPPLY

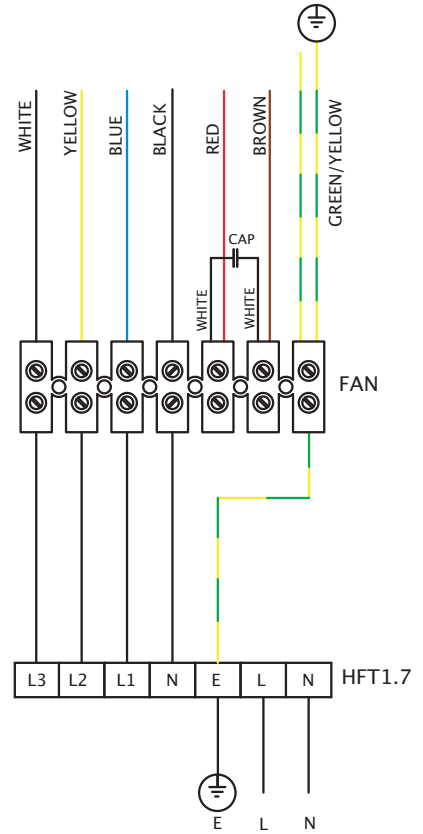

230V 1Ph 50 Hz SUPPLY

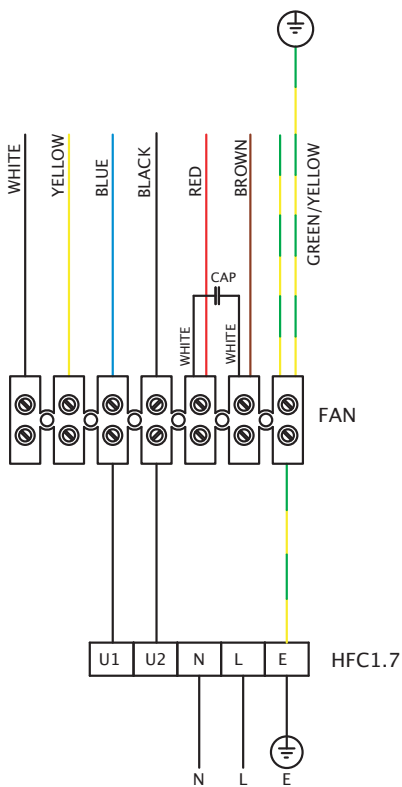

230V 1Ph 50 Hz SUPPLY

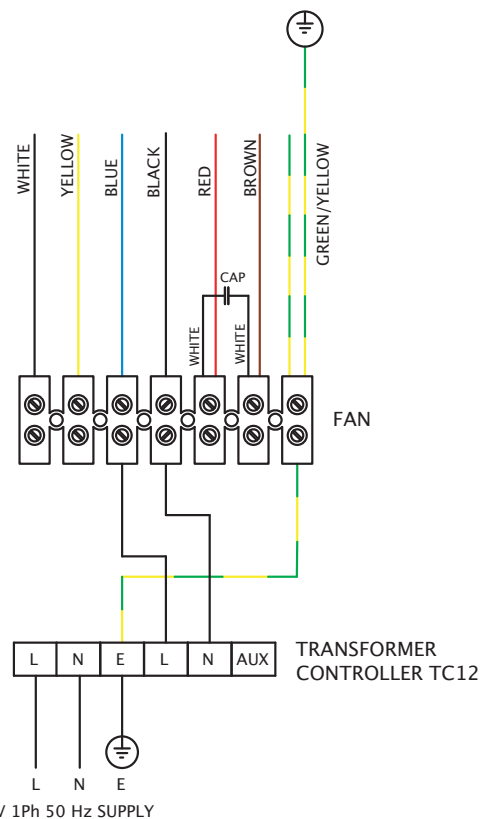

230V 1Ph 50 Hz SUPPLY

# Dimensional Data

2-HOLES IN EACH BRACKET  
 SIZES 100-160, Ø4  
 SIZES 200-315, Ø5

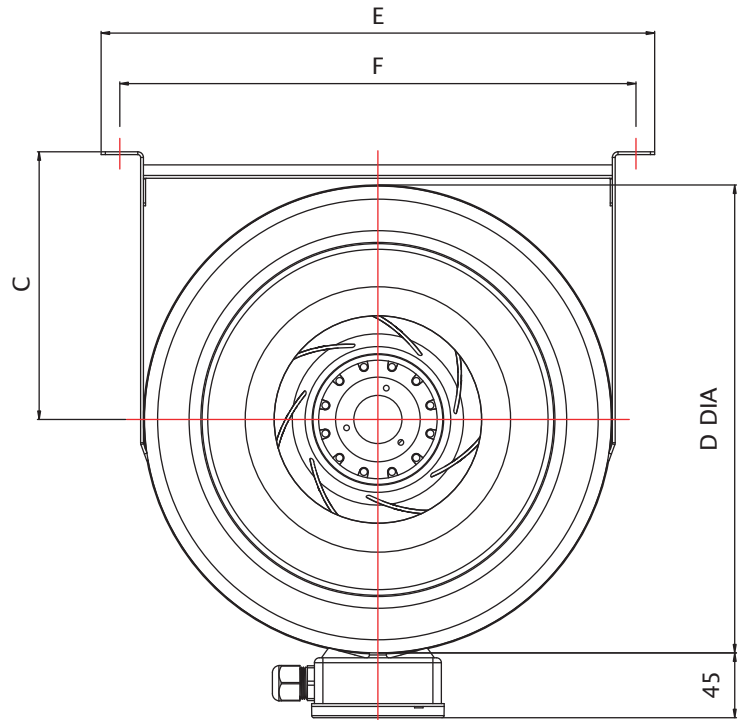
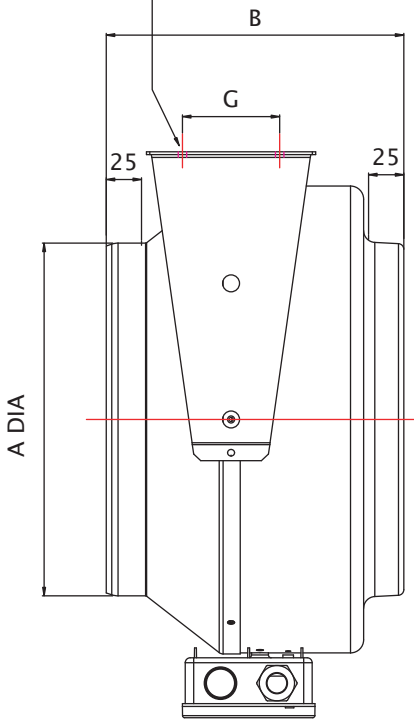

Product code	A	B	C	D	E	F	G	Weight kg
HIT100	98	204	130	236	284	270	47	3.7
HIT125	123	193	130	236	284	270	47	3.7
HIT150	148	195	165	278	326	312	47	3.6
HIT160	158	195	165	278	326	312	47	3.6
HIT200	198	235	190	333	392	372	100	5.5
HIT250	248	210	190	333	392	372	100	5.3
HIT250B	248	210	190	333	392	372	100	5.3
HIT315	313	265	227	400	460	440	100	8.1
HIT315B	313	265	227	400	460	440	100	8.8

# Accessories



## Voltage Controllers - Electronic HFC 1.7

An electronic voltage controller to provide stepless speed control.

Max FLC 1.7 Amps

IP51 0.3 kg

Dims: 110H x 110W x 60D

## Three Speed Controllers - HFT 1.7

A switch to provide three speed control.

Max FLC 1.7Amps

IP51 0.2 kg

Dims: 110H X 110W x 60D



## Voltage Controllers - Transformers TC12

A transformer voltage controller to provide five speed stop control.

Max FLC 2 Amps

IP40 3kg

Dims: 245H X 195W x 95D



## Flexible Connectors

Designed to fit directly to the fan spigot to provide a flexible inter-connection with any matched interface, for example ductwork. Flexible connectors are manufactured from PVC coated polyester, complete with banding clips.

Product Code	A	B	Weight kg
HFLXC100	100	150	0.2
HFLXC125	125	150	0.2
HFLXC150	150	150	0.2
HFLXC160	160	150	0.2
HFLXC200	200	150	0.3
HFLXC250	250	150	0.4
HFLXC315	315	150	0.5

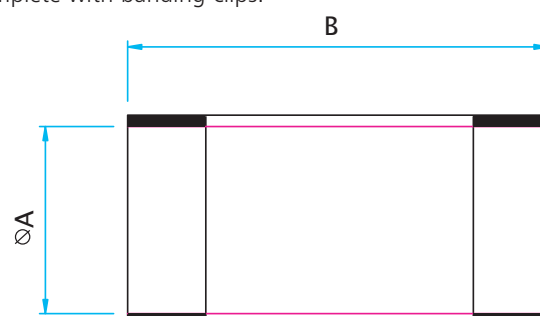

# Panel Filters

Panel filters are designed to provide a contaminant free air flow. Panel filters are available with filter media to BS EN 779 G3 with 85% arrestance. Filter access is via a removable panel. All casings are manufactured from galvanised sheet steel.

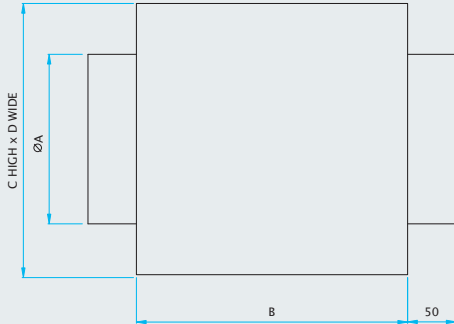
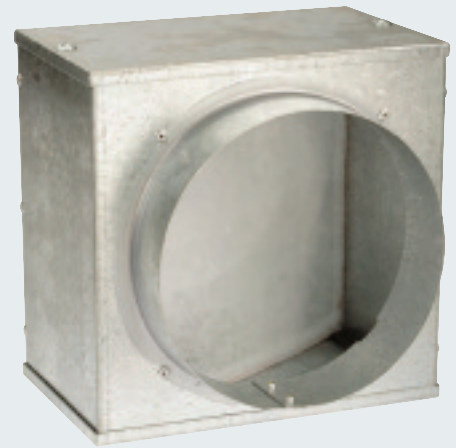

Product Code	A	B	C	D	Weight kg
HPFILT100	100	155	200	200	2
HPFILT125	125	155	200	200	2
HPFILT150	150	155	250	250	2
HPFILT160	160	155	250	250	2
HPFILT200	200	155	250	250	2
HPFILT250	250	200	300	300	3
HPFILT315	315	300	440	440	8

# Silencers

Silencers are specifically designed to be installed in air duct systems to control the air noise in the duct. Cylindrical silencers are suitable for use with HIT fans and general use in circular ducted systems. The casing is manufactured from galvanised mild steel with one piece spun ends. An inner lining of pre-galvanised, perforated mild steel encloses mineral fibre sound absorbing material with glass facing tissue.

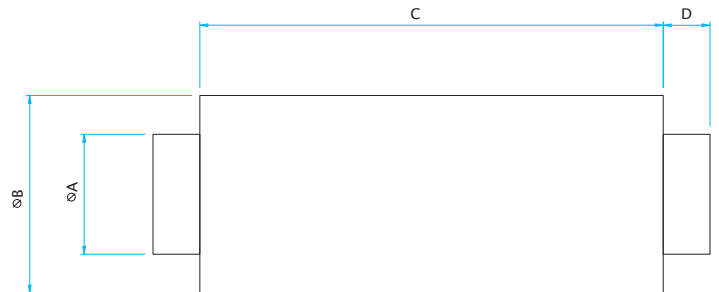

Product Code*	Fan Dia	A	B	C1	C2	C3	C4	D	Weight kg			
									1	2	3	4
HCS100-	100	98	204						2.5	4.6	6.7	8.7
HCS125-	125	123	230						2.9	5.4	7.8	10.2
HCS150-	150	148	255						3.4	6.1	8.9	11.6
HCS160-	160	158	265	300	600	900	1200	40	3.5	6.4	9.3	12.2
HCS200-	200	198	305						4.2	7.6	11.0	14.5
HCS250-	250	248	355						5.0	9.1	13.2	17.3
HCS315-	315	313	420						6.1	11.1	16.1	21.0

\* Add 1,2,3 or 4 depending on length required. Refer to page 9 for insertion losses.

# Heater Batteries

Safe and clean heating, max exit temperature is 40°C at 70% RHdB. Galvanised sheet steel case. Elements are nickel chromium wire insulated by compacted magnesium oxide powder within a stainless steel or incoloy tube and sealed by ceramic bead and silicon sealant. Air velocity min 2m/s, max 6m/s. Fitted with manual reset high temperature cutout.

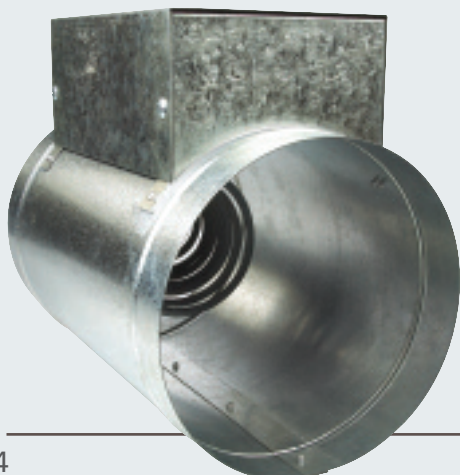
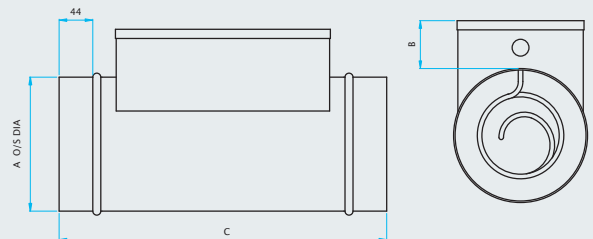

Product Code	kW	Stage	Phase	Airflow @ m³/s		A	B	C	Weight kg
				Min	Max				
HHB100	0.75	1	1	0.016	0.047	100	55	400	2
HHB125	1.0	1	1	0.025	0.074	125	80	400	2
HHB150	1.5	1	1	0.035	0.106	150	80	400	3
HHB160	1.5	1	1	0.04	0.12	160	80	400	3
HHB200	2.0	1	1	0.063	0.189	200	80	400	4
HHB250	3.0	1	1	0.098	0.295	250	80	400	4
HHB315	4.5	3/1	1/3	0.156	0.468	315	80	400	5

## Fast Clamps

For quick connection of spigotted fans to circular duct or accessories. Galvanised steel circular duct clamp with foam lining.

Product Code	Fan Dia	A	B
HFCLP100	100	92	116
HFCLP125	125	117	141
HFCLP150	150	142	166
HFCLP160	160	152	176
HFCLP200	200	192	216
HFCLP250	250	242	266
HFCLP315	315	307	331

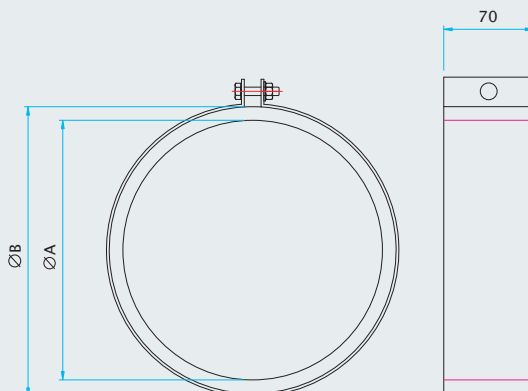

## Backdraught (Non-return) Dampers



Prevents reverse flow of air when fan not operating. Galvanised sheet steel case. Spring operated, aluminium sheet blades.

Product Code	Fan Dia A	B	C	Weight kg
HBS100	100	90	100	0.2
HBS125	125	90	100	0.3
HBS150	150	90	110	0.3
HBS160	160	90	100	0.3
HBS200	200	90	100	0.6
HBS250	250	90	100	0.6
HBS315	355	90	100	1.3

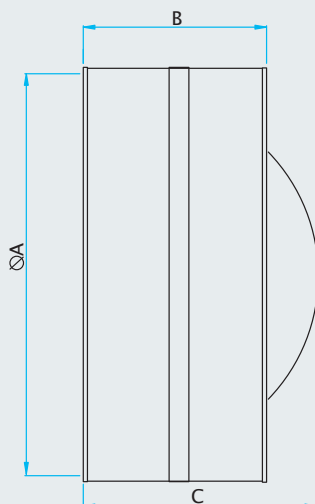

## Air Valves

HEV & HSV steel air valves present a straightforward and efficient way of providing discharge and supply of air. Mounting rings supplied complete with valve and a locking nut to maintain the airflow setting. Material construction is a durable white stove enamelled finish.

### Extract Valves HEV



## Supply Valves HSV

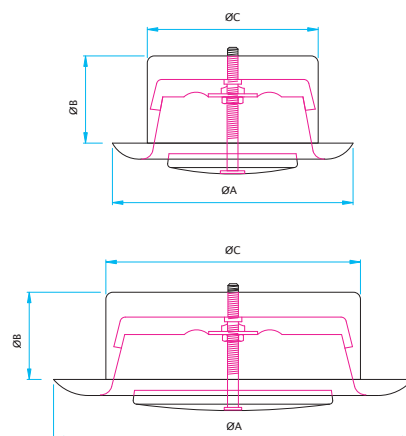
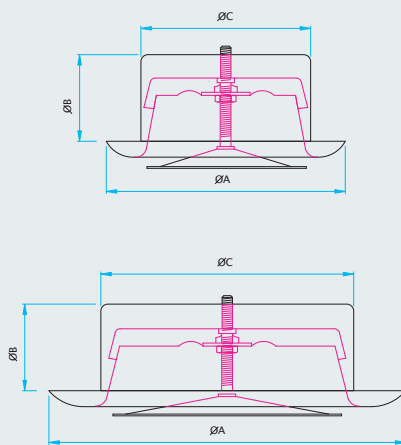

Product Code	A	B	C	Weight kg HSV	Weight kg HEV
HSE/HEV100	138	50	98	0.245	0.243
HSE/HEV125	166	50	123	0.306	0.305
HSE/HEV150	206	50	145	0.409	0.420
HSE/HEV200	250	50	196	0.606	0.604



[www.hydor.co.uk](http://www.hydor.co.uk)

Hydor Ltd · Unit 8 · Parkers Close · Downton Business Centre  
Downton · Salisbury · Wiltshire · SP5 3RB

Tel: +44 (0) 1725 511422 · Fax: +44 (0) 1725 512637

e-mail: [info@hydor.co.uk](mailto:info@hydor.co.uk) · [www.hydor.co.uk](http://www.hydor.co.uk)

HID/02-07-07/02

A member of the



FANS

CONTROLS

SYSTEMS