



Installation and Maintenance Instructions

HFC Electronic Speed Controllers

THESE INSTRUCTIONS MUST BE READ FULLY BEFORE COMMENCING INSTALLATION

Code	Supply	Max. Peak Current	H x W x Depth	IP Rating
HFC1.7	230V/1Ph/50Hz	1.7 Amps	108 x 108 x 60 mm	IP51
HFC3.0	230V/1Ph/50Hz	3.0 Amps	108 x 108 x 60 mm	IP51
HFC6.0	230V/1Ph/50Hz	6.0 Amps	108 x 108 x 60 mm	IP51

DESCRIPTION

Electronic variable speed fan controller suitable for use with single phase units.

INSTALLATION

All electrical installation must be carried out by suitably qualified and competent personnel in accordance with all current statutory requirements.

Check the details on the motor rating plate to ensure that the correct power supply (voltage, frequency and phase) is available. An incorrect power supply will lead to permanent damage of the unit.

Check that the number, size and speed of the fan(s) can safely be controlled by the controller supplied.

Connections are provided for one (1) fan outlet. If more than one fan is to be controlled then a correctly wired external junction box should be used.

The controller is only suitable for surface mounting and must not be recess mounted.

Install in a dry sheltered position. Do not install in close proximity to a heat source or in areas of high humidity. The maximum ambient temperature for the controller must not exceed 50° C (122° F).

WARNING! The controller must be isolated from the power supply during installation and maintenance.

Remove the front cover of the controller by unscrewing the cover fixing screws. This provides access to mounting holes and electrical terminals.

The controller must be connected to a suitably rated fused spur.

WIRING

Select the correct wiring diagram for the fan and controller supplied. All wiring and control equipment MUST comply with the latest IEE regulations, in particular 552-01-02/03.

In the event that the wiring connections for the fan supplied do not correspond to diagrams shown, please refer to the fan instructions or contact HYDOR for further assistance.

OPERATION

Switch on the controller by operating the ON/OFF rocker switch. Rotating the Control Knob clockwise will increase the speed of the fan(s) from a pre-set minimum (see below) to full speed (with infinitely variable speeds in between).

WARNING! Only a suitably qualified and competent person may carry out adjustment of the pre-set min speed control settings after the electrical supply has been isolated.

MINIMUM SPEED CONTROL SETTING

On certain fan types the factory set minimum speed might require adjustment. To adjust the minimum speed rotate the control knob on the front fully anti-clockwise. This is the current minimum speed position. Turn the minimum speed potentiometer inside the unit anti-clockwise to increase the minimum speed setting and turn clockwise to decrease the minimum speed setting. The fan will not fall below this pre-set speed during operation regardless of the front panel Control Knob setting. The minimum setting should not be less than 120V to ensure that the motor starts.

GUARANTEE

HYDOR will, free of charge, within a period of 1 year from the date of despatch from their works, repair or at its option replace any goods which are proved to have defects as a result of defective materials or workmanship. The goods MUST be returned to HYDOR carriage paid for examination.

WIRING

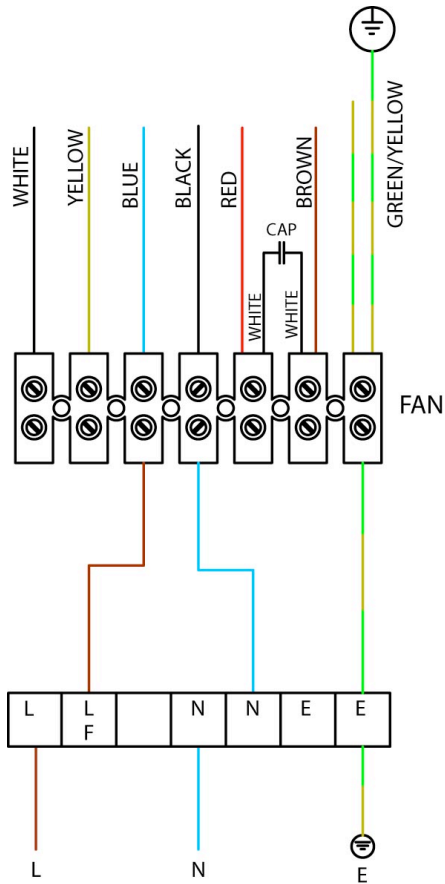

HIT FAN UNITS

THERMAL CUT-OUT
TO STARTER

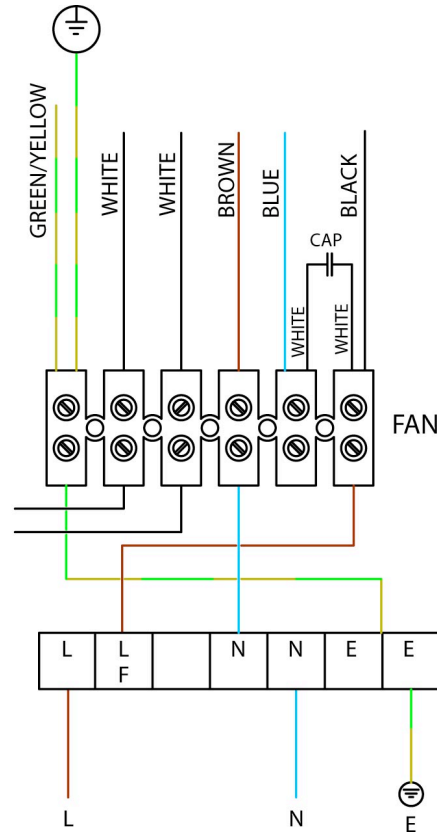

HP/HG FAN UNITS

GUARANTEE

HYDOR or its agents will, within a period of 1 year from the date of dispatch from their works, repair or, at its option, replace any goods, which are proven to have defects as a result of defective materials or workmanship. The goods MUST be returned to HYDOR, carriage paid, for examination.

Hydor Ltd.

8 Parkers Close, Downton Business Centre
Downton, Salisbury, Wiltshire
SP5 3RB, UK

TEL: +44 (0) 1725 511422 FAX: +44 (0) 1725 512637 email: info@hydor.co.uk

Hydor Ventilation Aust

42-62 Pound Road West
Dandenong South
Vic 3175

TEL: 1300 655 730 FAX: 1300 134 319 email: info@hydor.com.au

Hydor Ventilation SA

11 Ingrid Road
Montague Gardens
Capetown
7441

TEL: +27 (0) 21 552 1077 FAX: +27 (0) 21 552 2797 email: info@hydor.co.za