

### Ceiling Sweep Fan Fitting & wiring Instructions

**PLEASE READ ALL INSTRUCTIONS CAREFULLY BEFORE COMMENCING INSTALLATION**

This instruction leaflet covers the following sized fans

**900mm (36")**  
**1200mm (48")**  
**1400mm (56")**

All sizes are supplied with 2 downrod lengths  
400mm Downrod fitted giving 610mm overall drop  
(From ceiling to base of motor body)  
150mm Downrod supplied loose giving 360mm overall drop  
(From ceiling to base of motor body)

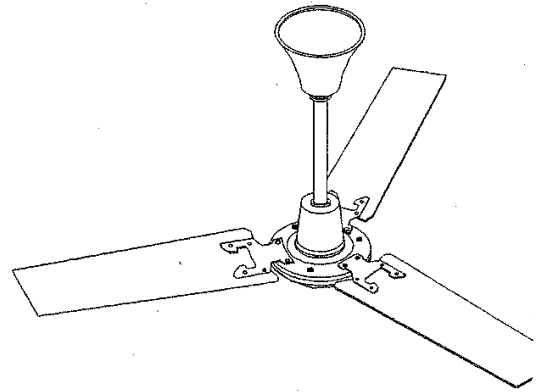

#### **IMPORTANT**

THE FAN MUST BE SITED AND CONNECTED IN ACCORDANCE WITH CURRENT IEE REGULATIONS (UK) OR THE APPROPRIATE STANDARDS IN YOUR COUNTRY.

THIS APPLIANCE MUST BE EARTHED

THE APPLIANCE IS NOT INTENDED FOR USE BY YOUNG CHILDREN OR INFIRM PERSONS WITHOUT SUPERVISION.

YOUNG CHILDREN SHOULD BE SUPERVISED TO ENSURE THAT THEY DO NOT PLAY WITH THE APPLIANCE.

CHECK THAT THE VOLTAGE AND FREQUENCY ON BOTH THE FAN MOTOR AND CONTROLLER (IF FITTED) RATING LABELS CORRESPOND WITH YOUR ELECTRICITY SUPPLY.

THE INSTALLATION MUST BE PROVIDED WITH A DOUBLE POLE ISOLATOR SWITCH HAVING A CONTACT SEPARATION OF NOT LESS THAN 3MM AND PROTECTED WITH A 5 AMP FUSE (UK).

ENSURE THAT THE SAFETY WIRE IS CONNECTED TO THE J-HOOK BRACKET BEFORE OPERATING FAN.

#### **INSTALLING THE CEILING FAN**

**(Ensure that the mains supply is isolated before proceeding with the wiring)**

1. Decide on the position the fan is to be sited; it must be a minimum of 2.3m from the floor to the lowest point on the fan. ( A shorter 150mm long downrod is supplied with the fan if required. Refer to the section on installing the shorter downrod).
2. Fix the ceiling J-hook (supplied) firmly to a timber joist or concrete ceiling with the coach screws supplied (Or similar). **Ensure that the fixing bracket in the ceiling is able to support a hanging weight of 15kg minimum.** (Fig A)
3. Fit the three blades to the fan body (see Diagram Fig B)
4. Hang the fan on the hook with the safety wire, then hook up the fan on the black rubber roller making sure that all wires are clear.
5. Connect supply wires to the fan using the terminal block at the top of the downrod. (See wiring Diagram Fig C)

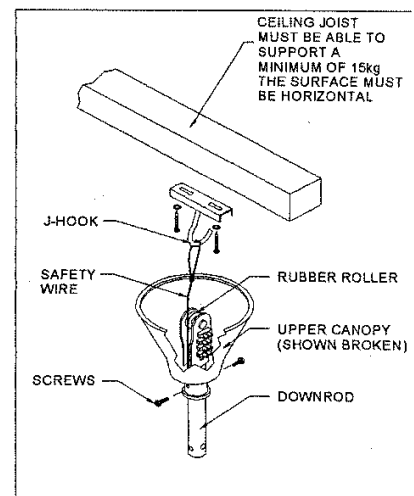

6. Secure upper canopy with the screws fitted to cover the wiring connections.
7. Tighten all screws including the earth connections.
8. Switch on supply and check fan function.

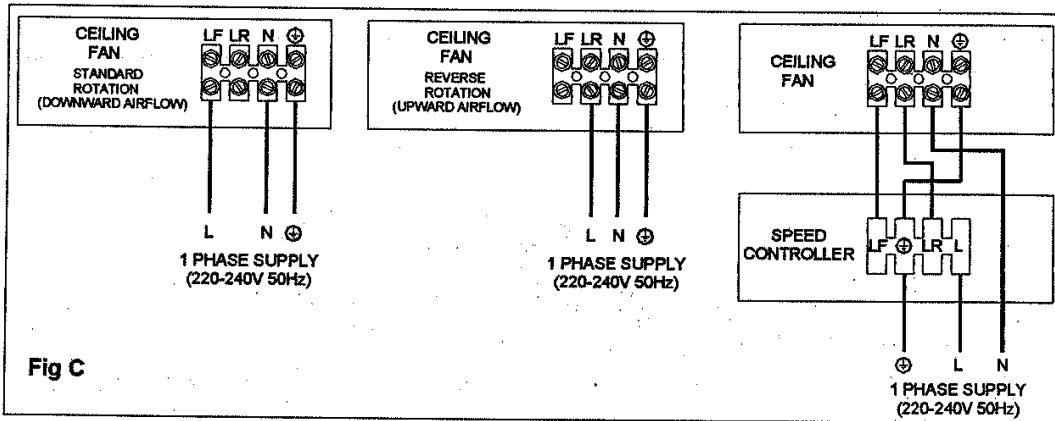
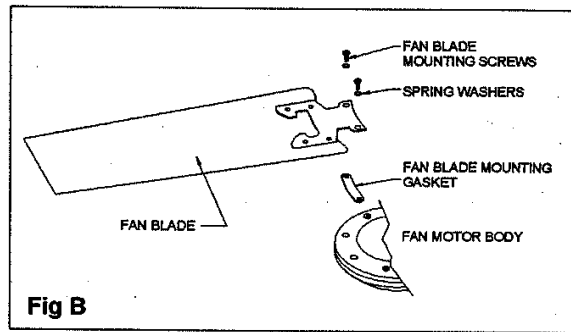

**INSTRUCTIONS FOR CHANGING TO SHORTER 150mm DOWNROD**  
**Ensure that the mains supply is isolated before proceeding**

1. Loosen the lower canopy screws and slide canopy up the downrod.
2. Disconnect the Brown (LF) Red (LR) and Blue (N), which run up the downrod from the lower terminal block located just above fan motor body.
3. Disconnect the Earth (Green/Yellow) wire from the lower mounting bracket which also runs up inside of downrod.
4. Carefully remove split pin and downrod securing bolt.
5. Loosen the upper canopy screws and slide canopy down the downrod.
6. Carefully remove the split pin and downrod securing bolt and then disconnect the Earth wire.
7. Carefully remove existing downrod passing the disconnected feed wires through the rod along with the safety wire.
8. Replace with the 150mm long downrod supplied.
9. Pass the feed wires through the new Rod along with the safety wire.
10. Replace the upper and lower downrod securing bolts and split pins.
11. The feed wires will need to be cut and stripped to suit the shorter rod. And re-connected as follows to the lower terminal block Brown (LF) Red (LR) and Blue (N).
12. Re-connect all Earth (Green/Yellow) wires.
13. Because the shorter downrod has been required for your particular installation, It is important that the safety wire is reduced in length to protrude 75mm above the Height of the 150mm downrod. The loop for the safety wire will need re-making by using a wire rope grip or crimp. (Supplied by others) It is essential that the new safety wire loop will withstand the weight of the fan in the event of it falling.

**IMPORTANT**  
**ALL FIXINGS MUST BE TIGHT BEFORE OPERATING THE FAN**  
**IT IS ADVISABLE TO CHECK/INSPECT ALL THE FIXINGS**  
**ANNUALLY, AND RE-TIGHTEN AS NECESSARY.**

This Fan is guaranteed for one year from date of purchase against Faulty material or workmanship. In the event of any part being found To be defective please contact your local supplier stating the nature of the fault and providing evidence of date and source of purchase.

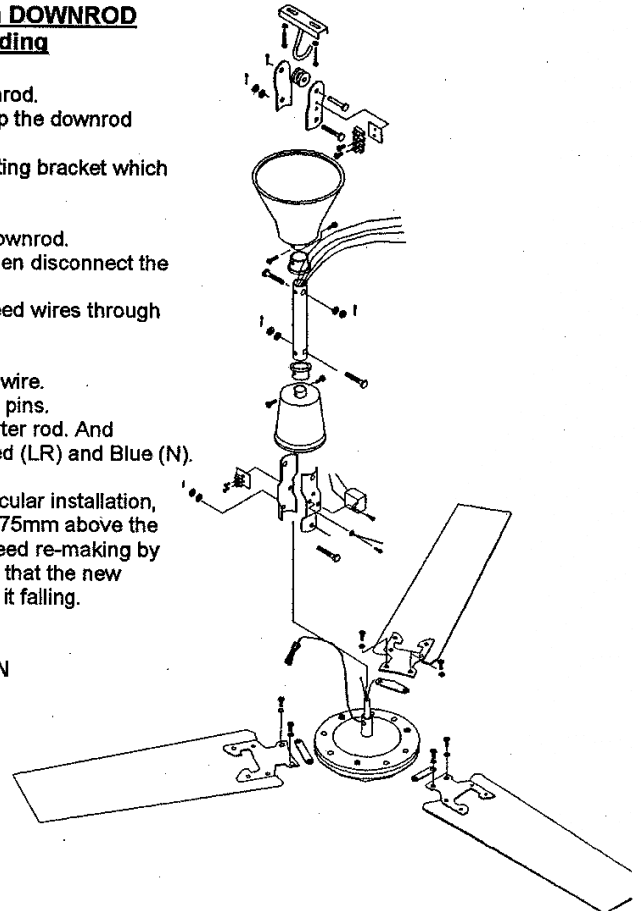

## **GUARANTEE**

**HYDOR or its agents will, within a period of 1year from the date of dispatch from their works, repair or, at its option, replace any goods, which are proven to have defects as a result of defective materials or workmanship. The goods MUST be returned to HYDOR, carriage paid, for examination.**

### **Hydor Ltd.**

8 Parkers Close, Downton Business Centre  
Downton, Salisbury, Wiltshire  
SP5 3RB, UK

TEL: +44 (0) 1725 511422    FAX: +44 (0)1725 512637    email: [info@hydor.co.uk](mailto:info@hydor.co.uk)

### **Hydor Ventilation Aust**

42-62 Pound Road West  
Dandenong South  
Vic 3175

TEL: 1300 655 730    FAX: 1300 134 319    email: [info@hydor.com.au](mailto:info@hydor.com.au)

### **Hydor Ventilation SA**

11 Ingrid Road  
Montague Gardens  
Capetown  
7441

TEL: +27 (0) 21 552 1077    FAX: +27 (0) 21 552 2797    email: [info@hydor.co.za](mailto:info@hydor.co.za)